



Yes, You Can.®



Invacare® Spectra XTR

*Electric wheelchair
Instruction manual*



How can you get in touch with Invacare®?

If you have any questions or need support, please contact your authorised Invacare® Dealer, who has the necessary know-how and equipment plus the special knowledge concerning your Invacare® product, and can offer you all-round satisfactory service. Should you wish to contact Invacare® directly, you can reach us in Europe at the following addresses and phone numbers.

A	Mobitec Mobilitätshilfen GmbH Herzog Odilostrasse 101 A-5310 Mondsee Austria	☎ Fax: @: @: WWW:	+43 - 6232 - 55 35 0 +43 - 6232 - 55 35 4 office@mobitec-austria.com austria@invacare.com www.mobitec-austria.com
----------	---	-------------------------------	---

B	Invacare® n.v. Autobaan 22 B-8210 Loppem (Brugge)	☎ Fax: @: WWW:	+32 - (0)50 - 83 10 10 +32 - (0)50 - 83 10 11 belgium@invacare.com www.invacare.be
----------	--	-------------------------	---

CH	Mobitec Rehab AG Benkenstraße 260 CH-4108 Witterswil Switzerland	☎ Fax: @: @: WWW:	+41 - (0)61 - 48 77 08 0 +41 - (0)61 - 48 77 08 1 office@mobitec-rehab.ch switzerland@invacare.com www.mobitec-rehab.ch
-----------	---	-------------------------------	---

D	Invacare Aquatec Alemannenstraße 10 88316 Isny Deutschland	☎ Fax: @: WWW:	0 75 62 / 7 00 - 251 08 00 / 6 73 81 72 info@invacare-aquatec.de www.invacare-aquatec.de
----------	---	-------------------------	---

DK	Invacare® A/S Sdr. Ringvej 39 DK-2605 Brøndby Danmark	☎ (Kundeservice): Fax (Kundeservice): @: WWW:	+45 - (0)36 - 90 00 00 +45 - (0)36 - 90 00 01 denmark@invacare.com www.invacare.dk
-----------	--	--	---



Invacare® SA
 c/ Areny, s/n
 Poligon Industrial de Celrà
 17460 Celrà (Girona)
ESPAÑA

☎ : +34 - (0)972 - 49 32 00
 Fax: +34 - (0)972 - 49 32 20
 @: contactsp@invacare.com
 WWW: www.invacare.es



Invacare® Poirier SAS
 Route de St Roch
 F-37230 Fondettes
France

☎ : +33 - (0)247 - 62 64 66
 Fax : +33 - (0)247 - 42 12 24
 @: contactfr@invacare.com
 WWW: www.invacare.fr



Invacare® Ltd
 South Road
 Bridgend Industrial Estate
 Mid Glamorgan - CF31-3PY
United Kingdom

☎ (Customer Service): +44 - (0)1656 - 664 321
 Fax (Customer Service): +44 - (0)1656 - 667 532
 @: uk@invacare.com
 @: eire@invacare.com
 WWW: www.invacare.co.uk



Invacare Mecc San s.r.l.
 Via Dei Pini, 62
 I - 36016 Thiene (VI)
ITALIA

☎ : +39 - 0445 - 38 00 59
 Fax: +39 - 0445 - 38 00 34
 @: italia@invacare.com
 WWW: www.invacare.it



Invacare Ireland Ltd.
 Unit 5 Seatown Business Campus
 Seatown Rd, Swords
 County Dublin
Ireland

☎ : +353 - 18 10 70 84
 Fax: +353 - 18 10 70 85
 @: eire@invacare.com



Invacare® AS
 Grensesvingen 9
 Postboks 6230
 N-0603 Oslo
Norge

☎ (Kundeservice): +47 - (0)22 57 95 10
 Fax (Kundeservice): +47 - (0)22 57 95 01
 @: norway@invacare.com
 WWW: www.invacare.no



Invacare® B.V.
Celsiusstraat 46
NL-6716 BZ Ede
Nederland

☎ : +31 - (0)318 - 69 57 57
Fax: +31 - (0)318 - 69 57 58
@: nederland@invacare.com
WWW: www.invacare.nl



Invacare Portugal, Lda
Rua Estrada Velha, 949
4465-784 Leça do Balio
Portugal

☎ : +351-225105946
Fax: +351-225105739
@: portugal@invacare.com
WWW: www.invacare.pt



Aterförsäljare:
Invacare® AB
Fagerstagatan 9
S-163 91 Spånga
Sverige

☎ (Kundtjänst): +46 - (0) 8 761 70 90
Fax (Kundtjänst): +46 - (0) 8 761 81 08
@: sweden@invacare.com
@: finland@invacare.com
WWW: www.invacare.se



Tillverkare:
Invacare® Deutschland GmbH
Kleiststraße 49
D-32457 Porta Westfalica
Deutschland

MÖLNDAL
☎ +46 - (0) 31 – 86 36 00
Fax: +46 - (0) 31 – 86 36 06
@: ginvacare@invacare.com

LANDSKRONA
☎ +46 - (0) 418 – 285 40
Fax: +46 - (0) 418 – 180 89
@: linvacare@invacare.com

OSKARSHAMN
☎ +46 - (0) 491 – 101 40
Fax: +46 - (0) 491 – 101 80
@: oinvacare@invacare.com

Table of Contents

Chapter		Page
1	Introduction	11
1.1	Important symbols in this manual	13
1.2	Important symbols found on the vehicle	14
1.3	Type classification and permissible use.....	16
1.4	Guarantee	16
1.5	Indications.....	17
1.6	Life expectancy.....	17
2	Safety Notes	18
2.1	General Safety Notes	18
2.2	Safety information with regard to care and maintenance	21
2.3	Safety Information on Electromagnetic Interference.....	22
2.4	Safety Information on Driving and Freewheel Mode.....	23
3	Key features	25
4	Getting in and out of the wheelchair	26
4.1	Using the cane holder	26
4.2	Removing the armrests to get in	27
4.2.1	Standard seat / firm seat.....	27
4.2.2	Flex II seat	28
5	Driving	30
5.1	Before driving for the first time.....	30
5.2	Parking and stationary.....	31

5.2.1	Parking brakes.....	31
5.3	Taking Obstacles	32
5.3.1	Maximum obstacle height.....	32
5.3.2	Safety information when ascending obstacles	33
5.3.3	The correct way to overcome obstacles	33
5.4	Driving up and down gradients.....	34
6	Pushing the mobility device in freewheel mode	35
6.1	Disengaging motors.....	35
7	Remotes	37
8	Adjusting the wheelchair to the user's seating posture	38
8.1	Adjusting the armrests and the joystick box.....	39
8.1.1	Adapting the remote to the length of the user's arm	39
8.1.2	Setting the height of the remote	40
8.1.2.1	High-End remote holder	40
8.1.3	Swivelling the remote to the side.....	41
8.1.4	Setting the height of the armrests.....	42
8.1.4.1	Firm seat unit.....	42
8.1.4.2	Standard Seat unit.....	45
8.1.5	Setting the Hemi armrest rotation	46
8.1.6	Adjusting the width of the armrests	47
8.1.6.1	Firm seat unit.....	47
8.1.6.2	Standard Seat unit.....	48
8.1.6.3	Flex II seat unit	49
8.2	Adjusting the seat angle	50
8.2.1	Electric	50
8.2.2	Manually using spindle	50
8.3	Adjusting the backrest.....	52
8.3.1	Adjusting the backrest angle using the perforated plate (standard seat)	52

8.3.2	Adjusting the backrest (firm seat).....	53
8.3.2.1	Electric.....	53
8.3.2.2	Manual.....	53
8.3.3	Adjusting the backrest using the gas pressure spring (Flex II seat).....	54
8.3.4	Adjusting the tension adjustable backrest upholstery.....	55
8.4	The Lifter.....	56
8.4.1	Explanation of symbols on lifter warning sticker.....	57
8.5	Adjusting the headrest.....	58
8.5.1	Adjusting the position of the headrest or neckrest.....	59
8.5.2	Adjusting the height of the headrest or neckrest.....	60
8.5.3	Adjusting the position of the headrest with cheek support sideways.....	61
8.5.4	Adjusting the cheek supports.....	62
8.6	Postural belts.....	63
8.6.1	Types of postural belts.....	63
8.6.2	Adjusting the postural belt correctly.....	64
8.7	Adjusting the trunk support (Flex II seat / firm seat).....	65
8.7.1	Adjusting the width.....	65
8.7.2	Adjusting the height.....	66
8.7.3	Adjusting the depth.....	67
8.8	Adjusting the height-adjustable push handle (Flex II seat).....	68
8.9	Adjusting and removing the tray.....	69
8.9.1	Laterally adjusting the tray.....	69
8.9.2	Adjusting the depth of the tray / removing the tray.....	70
8.9.3	Swinging the tray away to the side.....	70

9 Adjusting footrests and legrests 72

9.1	Legrests or footrests attached to the side.....	72
9.1.1	Vari-F footrest.....	72
9.1.1.1	Swivelling the footrest outward and/or removing.....	72
9.1.1.2	Setting the angle.....	73
9.1.1.3	Setting the end stop of the footrest.....	75

9.1.1.4	Adjusting the length of the footrest.....	78
9.1.2	Vari-A legrests	79
9.1.2.1	Swivelling the legrest outward and/or removing.....	79
9.1.2.2	Setting the angle.....	80
9.1.2.3	Setting the end stop of the legrest.....	81
9.1.2.4	Adjusting the length of the legrest	84
9.1.2.5	Adjusting the depth of the calf plate	85
9.1.2.6	Adjusting the height of the calf plate	86
9.1.2.7	Unlocking and swivelling the calf plate backward when alighting	87
9.1.2.8	Adjusting the angle adjustable foot plate.....	88
9.1.2.9	Adjusting the angle and depth adjustable foot plate	89
9.1.3	ADE legrests.....	90
9.1.3.1	Swivelling the legrest outward and/or removing.....	90
9.1.3.2	Setting the angle.....	91
9.1.3.3	Adjusting the length of the legrest	92
9.1.3.4	Adjusting the depth of the calf plate	93
9.1.3.5	Adjusting the height of the calf plate	94
9.1.3.6	Unlocking and swivelling the calf plate backward when alighting	95
9.1.3.7	Adjusting the angle adjustable foot plate.....	96
9.1.3.8	Adjusting the angle and depth adjustable foot plate	97
9.1.4	Standard 80° footrest.....	98
9.1.4.1	Swivel the footrests outwards and/or remove them	98
9.1.4.2	Adjusting the length	100
9.1.5	Manually height-adjustable legrest	101
9.1.5.1	Swivelling the legrest outward and/or removing.....	101
9.1.5.2	Setting the angle.....	102
9.1.5.3	Adjusting the length of the legrest	103
9.1.5.4	Adjusting the depth of the calf plate	104
9.1.5.5	Adjusting the height of the calf plate	105
9.1.6	Adjusting the width of the legrests fixed to the side (Standard / Flex II seat).....	106
9.2	Legrests for the firm seat	107

9.2.1	Modifying the seat depth in the front by adjusting the position of the legrest support brackets	107
9.2.2	Standard / Junior / Mini Legrests (firm seat).....	108
9.2.2.1	Adjusting the length of the legrest	108
9.2.3	Angle adjustable legrest	109
9.2.3.1	Adjusting the angle of the legrest	109
9.2.3.2	Adjusting the length of the legrest	111

10 Electrical System 112

10.1	Electronics Protection System	112
10.2	Batteries	113
10.2.1	What you need to know about batteries	113
10.2.2	Charging the batteries	115
10.2.3	How to handle damaged batteries correctly	116

11 Maintenance 117

11.1	Cleaning the mobility device	117
11.2	Inspection checks	118
11.2.1	Before each use of the mobility device.....	119
11.2.2	Weekly	120
11.2.3	Monthly	121
11.3	Repair Instructions.....	122
11.3.1	Repairing a flat tyre	122
11.3.1.1	Repairing a flat tyre at the front (tyre type 280/250-4).....	123
11.3.1.2	Repairing a flat tyre at the rear (wheel rim type 3.00-8").....	125

12 Transport 129

12.1	Transferring the wheelchair to a vehicle.....	130
12.2	Use of the wheelchair as a seat in a vehicle.....	131
12.2.1	How the wheelchair is anchored in a vehicle for use as a vehicle seat	133
12.2.2	How the user is secured within the wheelchair.....	134

12.3	Transporting the wheelchair without occupants	138
12.3.1	Preparing the wheelchair for transport without occupants.	138
12.3.1.1	Removing the batteries.....	139
12.3.1.2	Folding the backrest forwards (standard seat).....	141
12.3.1.3	Removing the seat (not possible for versions fitted with lifter)	142
12.3.1.4	Reassembling the wheelchair.....	144
12.3.1.5	Special information about reassembly	145
13	Refurbishment	149
14	Disposal	150
15	Technical Specifications	151
16	Inspections Performed	155

1 Introduction

Dear user,

First we would like to thank you for purchasing our product! We hope that you will have a great deal of pleasure with your new power chair.

This operating manual contains important information and notes about:

- **Safety**
- **Operation**
- **Care and maintenance**

Please take care to read the operating manual thoroughly before starting out on your first journey.

This wheelchair has been constructed for a large circle of users with different requirements.

The decision whether the model is suitable for the user may only be taken by medical specialists with appropriate expertise.

Invacare® or their statutory representatives can accept no liability in cases in which the wheelchair has not been adapted to suit the users' handicaps.

Some maintenance and settings can be performed by the user or his/hers attendants. Certain adjustments do however require technical training and may only be carried out by your Invacare® specialist dealer. Damages and errors caused by nonobservance of the operating manual or as a result of incorrect maintenance are excluded from all guarantees.

This manual contains copyrighted information. This manual may not be reproduced or reprinted either partly or completely without previous written consent from Invacare® or its statutory representatives. We reserve the right to make any necessary alterations on the grounds of technical improvements.

1.1 Important symbols in this manual



WARNING!

This symbol warns you of danger!

- *Always follow these instructions to avoid injury to the user or damage to the product!*
-



EXPLOSION HAZARD!

This symbol warns you of an explosion hazard, which, for example, can be caused by excessive tyre pressure in a pneumatic tyre!

- *Always follow the instructions to avoid injury to the user or damage to the product!*
-



BURN HAZARD!

This symbol warns you of burns due, for example, to leaking battery acid!

- *Always follow the instructions to avoid injury to the user or damage to the product!*
-



NOTE:

This symbol identifies general information which is intended to simplify working with your product and which refers to special functions.



Requirements:

- This symbol identifies a list of various tools, components and items which you will need in order to carry out certain work.
-



READ WELL BEFORE OPERATION!

This symbol advises you to read information carefully.

1.2 Important symbols found on the vehicle



This product has been supplied from an environmentally aware manufacturer that complies with the Waste Electrical and Electronic Equipment (WEEE) Directive 2002/96/CE. This product may contain substances that could be harmful to the environment if disposed of in places (landfills) that are not appropriate according to legislation.

- *The 'crossed out wheelie bin' symbol is placed on this product to encourage you to recycle wherever possible.*
 - *Please be environmentally responsible and recycle this product through your recycling facility at its end of life.*
-



This symbol indicates the position of an anchoring point for use with a tie-down system.

If the symbol appears on a bright yellow sticker, the anchoring point is suitable for fixation of the wheelchair in a vehicle for use as a vehicle seat.

If the symbol appears on a transparent sticker, the anchoring point can only be used to tie down the wheelchair for transport without the occupant seated in it.



This symbol indicates the maximum width to which an armrest may be adjusted. Pulling the armrest out further can cause it to fall out of its fixation. For further information, see chapter "Adjusting the width of the armrests" on page 47.



If the electric wheelchair is fitted with a table, it is imperative that it is removed and safely stowed when transporting the wheelchair in a vehicle!

1.3 Type classification and permissible use

This vehicle was designed for persons whose ability to walk is impaired, but who are still physically and mentally able to operate an electric vehicle. It has been classified according to EN 12184 as a **class B mobility product** (for indoor and outdoor areas). It is therefore compact and agile enough for indoor areas, but also able to overcome many obstacles in outdoor areas.

You can find exact information on speed, turning radius, range, safe climbing ability, maximum obstacle height and permissible operating conditions in chapter "**Technical Specifications**" starting from page 151.

Please also pay attention to all safety information in chapter "**Safety Notes**" starting from page 18.

The vehicle was successfully tested according to German and international standards as to its safety. It was also tested successfully according to EN60529 IPX4 as to its resistance to spray water, and is therefore well suited for typical middle European weather conditions. When equipped with an appropriate lighting system, the vehicle is suitable for use on public roads.

1.4 Guarantee

The terms and conditions of the guarantee are part of the general terms and conditions particular to the individual countries in which this product is sold.

1.5 Indications

The use of this mobility product is recommended for the following indications:

The inability or a greatly restricted ability to walk within the scope of the basic requirement to be able to move within one's own four walls. The need to leave the dwelling place in order to get some fresh air during a short walk or to reach those places generally to be found at close distance to the dwelling and where everyday business is carried out.

Provision of electric wheelchairs for interior and exterior areas is advisable if the use of hand-operated wheelchairs is no longer possible on account of the disability, yet proper operation of an electromotive drive unit is still practicable.

1.6 Life expectancy

We estimate a life expectancy of five years for this product, provided it is used in strict accordance with the intended use as set out in this document and all maintenance and service requirements are met. The estimated life expectancy can be exceeded if the product is carefully used and properly maintained, and provided technical and scientific advances do not result in technical limitations. The life expectancy can also be considerably reduced by extreme or incorrect usage. The fact that we estimate a life expectancy for this product does not constitute an additional warranty.

2 Safety Notes



READ WELL BEFORE OPERATION!

2.1 General Safety Notes



Danger of injury if mobility device is used in any other way than the purpose described in this manual!

- *Only ever use the mobility device in accordance with the instructions in this User's Manual (see chapter "Type classification and permissible use" on page 16).*
- *Pay strict attention to the safety information.*

Danger of injury if the mobility device is driven when ability to operate a vehicle is impaired by medication or alcohol!

- *Never drive the mobility device under the influence of medication or alcohol. If necessary, the mobility device must be operated by an attendant who is physically and mentally able.*

Danger of damage or injury if mobility device is accidentally set into motion!

- *Switch the mobility device off before you get in, get out or handle unwieldy objects.*
 - *When the drive is disengaged, the brake inside the drive is deactivated. For this reason, pushing the mobility device by an attendant is only recommended on flat surfaces, never on gradients. Never leave your mobility device on a gradient with its motors disengaged. Always re-engage the motors immediately after pushing the mobility device (see chapter "Pushing the mobility device in freewheel mode" on page 35).*
-



Danger of injury if the mobility device is switched off while driving, for example by pressing the On/Off Button or disconnecting a cable, due to it coming to an abrupt, sharp stop!

- *If you have to brake in an emergency, simply release the joystick which will bring you to a halt. (refer to the joystick operating manual for more information).*

Danger of injury when transferring mobility device to a vehicle for transport with the occupant seated in it!

- *It is always better to transfer the mobility device to a vehicle without the occupant seated in it.*
- *If the mobility device needs to be loaded up a ramp together with its driver, ensure that the ramp does not exceed the maximum safe slope (see chapter "Technical Specifications" from page 151).*
- *If the mobility device does need to be loaded using a ramp which exceeds the maximum safe slope (see chapter "Technical Specifications" from page 151), then you must use a winch. An attendant can safely monitor and assist the loading process.*
- *As an alternative you can use a platform lift. Ensure that the total weight of the mobility device including the user does not exceed the maximum permissible weight for the platform lift or winch if you are using.*

Danger of injury if maximum permissible load is exceeded!

- *Do not exceed the maximum permissible load (see chapter "Technical Specifications" from page 151).*
 - *The mobility device is only designed for use by a single occupant whose maximum weight does not exceed the maximum permissible load of the chair. Never use the mobility device to transport more than one person.*
-



Danger of injury due to wrong lifting or dropping of heavy components!

- *When maintaining, servicing or lifting any part of your mobility device, take into account the weight of the individual components especially the batteries. Be sure at all times to adopt the correct lifting posture and ask for assistance if necessary.*

Danger of falling out of the mobility device.

- *Do not slide forward on the seat, do not lean forward between your knees, do not lean backwards out over the top of the backrest, for example to reach an object.*
- *If a posture belt is installed, it should be correctly adjusted and used each time you use the mobility device.*
- *When transferring to a different seat, position the mobility device as close as possible to the new seat.*

Danger of injury by moving parts!

- *Make sure that no injury is incurred by moving parts of the mobility device, like wheels or one of the Lifter Modules (if fitted), especially when children are around.*

Danger of fire or breaking down due to electric devices being connected!

- *Do not connect any electric devices to your mobility device that are not expressly certified by Invacare® for this purpose. Have all electrical installations done by your authorised Invacare® Dealer.*
-

2.2 Safety information with regard to care and maintenance



Danger of accident and loss of guarantee if maintenance is insufficient!

- *For reasons of safety and in order to avoid accidents which result from unnoticed wear, it is important that this electric mobility product undergoes an inspection once every year under normal operating conditions (see inspection plan contained in service instructions).*
 - *Under difficult operating conditions such as daily travel on steep slopes, or in the case of use in medical care cases with frequently changing wheelchair users, it would be expedient to carry out intermediate checks on the brakes, accessories and running gear.*
 - *If the mobility product is to be operated on public roads, the vehicle driver is responsible for ensuring that it is in an operationally reliable condition. Inadequate or neglected care and maintenance of the mobility product will result in a limitation of the manufacturer's liability.*
-

2.3 Safety Information on Electromagnetic Interference

This electric vehicle was successfully tested in accordance with International standards as to its compliance with Electromagnetic Interference (EMI) Regulations. However, electromagnetic fields, such as those generated by radio and television transmitters, and cellular phones, can influence the functions of electric vehicles. Also, the electronics used in our vehicles can generate a low level of electromagnetic interference, which however will remain within the tolerance permitted by law. For these reasons we ask you to please observe the following precautions:



WARNING: Danger of malfunction due to electromagnetic interference!

- *Do not switch on or operate portable transceivers or communication devices (such as radio transceivers or cellular phones) when the vehicle is switched on.*
 - *Avoid getting near strong radio and television transmitters.*
 - *In case the vehicle should be set in motion unintentionally or the brakes are released, switch it off immediately.*
 - *Adding electrical accessories and other components or modifying the vehicle in any way can make it susceptible to electromagnetic interference. Keep in mind that there is no sure way to determine the effect such modifications will have on the overall immunity of the electronic system.*
 - *Report all occurrences of unintentional movement of the vehicle, or release of the electric brakes to the manufacturer.*
-

2.4 Safety Information on Driving and Freewheel Mode



Danger of injury if the wheelchair tips over!

- *Inclines and declines can only be travelled up to the maximum safe slope (see chapter "Technical Specifications" from page 151).*
 - *Always return the backrest of your seat or the seat tilt to an upright position before ascending slopes. We recommend that you position the seat backrest and the seat tilt (if fitted) slightly to the rear before descending slopes.*
 - *Only ever drive downhill at a maximum of 2/3 of the top speed. Avoid abrupt braking or accelerating on gradients.*
 - *If at all possible, avoid driving on slippery surfaces (such as snow, gravel, ice etc.) where there is a danger of you losing control over the vehicle, especially on a gradient. If driving on such a surface is inevitable, then always drive slowly and with the utmost caution.*
 - *Never attempt to overcome an obstacle when on an uphill or downhill gradient.*
 - *Never attempt to drive up or down a flight of steps with your wheelchair.*
 - *When overcoming obstacles, always observe the maximum obstacle height (see chapter "Technical Specifications" from page 151 and information about overcoming obstacles in chapter "Taking Obstacles" from page 32).*
 - *Avoid shifting your centre of gravity as well as abrupt joystick movements and changes of direction when the wheelchair is in motion.*
 - *Never use the wheelchair to transport more than one person.*
 - *Do not exceed the overall maximum permissible load or the maximum load per axle (see chapter "Technical Specifications" on page 151).*
 - *Note that the wheelchair will brake or accelerate if you change the Driving Mode whilst the wheelchair is in motion.*
-



Danger of breaking down in adverse weather conditions, i.e. extreme cold, in an isolated area!

- *If you are a user with severely limited mobility, we advise that in the case of adverse weather conditions DO NOT attempt a journey without an accompanying attendant!*

Danger of injury if your foot slides off the footrest and gets caught underneath the wheelchair when it is in motion!

- *Make sure each time before you drive the wheelchair that your feet are squarely and securely in place on the footplates, and that both legrests are properly locked into place.*

Danger of injury if you collide with an obstacle when driving through narrow passages such as doorways and entrances!

- *Drive through narrow passages in the lowest driving mode and with due caution.*

If your electric wheelchair has been fitted with angle-adjustable legrests, there is a danger of personal injury and damage to the wheelchair if you drive the wheelchair with the legrests raised!

- *To avoid unwanted displacement of the wheelchair centre of gravity to the front (especially when travelling downhill) and in order to avoid damage to the wheelchair, angle-adjustable legrests must always be lowered during normal travelling.*
-



CAUTION: Tipping hazard if anti-tip wheels (1) are removed, damaged or changed to a position different to the factory settings!

- *Anti-tip wheels should only ever be removed for dismantling the wheelchair for transport in a vehicle or for storage.*
- *The anti-tip wheels must always be fitted if the wheelchair is being used.*



3 Key features

- 1) Push handle
- 2) Armrest
- 3) Drive wheel
- 4) Lever for disengaging a motor (only visible on right-hand side of picture)
- 5) Remote
- 6) Legrests



4 Getting in and out of the wheelchair



Important information for getting into and out of the wheelchair from the side!

The armrest must be removed in order to get into or out of the wheelchair from the side.

4.1 Using the cane holder

If your mobility device is fitted with a cane holder, then this can be used to safely transport your walking cane or crutches with you wherever you go. The cane holder consists of a lower plastic holder and an upper Velcro fastener.



CAUTION! Injury hazard! Transporting a walking cane or crutches laying loosely across the user's lap or in an otherwise unsecured fashion can pose an injury risk to the user and bystanders!

- *Always use a cane holder to transport a cane or crutches!*
-
- Open the upper Velcro fastener.
 - Place the bottom end of the cane or crutch in the lower holder.
 - Use the upper Velcro fastener to secure the cane or crutch in place.

4.2 Removing the armrests to get in

The armrest is either fixed with a locking pin or a locking screw, depending on the version. If you intend to get into the mobility device on the side that the remote is on, then depending on the remote version you may be able to detach the remote cable.

4.2.1 Standard seat / firm seat

Removing the armrest:

- The remote cable (1) can be removed from remote depending on the remote version.
- Loosen wing nut (2)
- Remove the side panel from the receptacle



4.2.2 Flex II seat

Removing the armrest:

- Loosen remote cable (1) from remote.
- Push the locking pin (2) in.
- Remove the side panel from the holder tube.



Getting into the wheelchair:

- Position your wheelchair as close as possible to your seat. This might have to be done by an attendant.
- Switch your wheelchair off.
- Apply the manual wheel lock of your wheelchair (if existing).
- Detach the skirt guard of your wheelchair or swivel it up.
- Now slide into the wheelchair.



Getting out of the wheelchair:

- Drive your wheelchair as close as possible to your seat.
- Switch your wheelchair off.
- Apply the manual wheel lock of your wheelchair (if existing).
- Detach the skirt guard of your wheelchair or swivel it up.
- Now slide onto your new seat.



NOTE:

If you do not have sufficient muscle strength, you should ask other persons for help. Use a sliding board, if possible.

5 Driving



NOTE

The maximum load capacity that is stated in the technical data only states that the system is designed for this mass in total. However, this does not mean that one can sit a person with this body weight in the wheelchair without restrictions. Attention must be paid to the body proportions, such as height, weight distribution, abdominal girth, leg and calf girth and seat depth. These factors have a strong influence on driving features such as tilt stability and traction. The permissible axle loads in particular must be adhered to (see chapter "**Technical Specifications**" as from page **151**)! It may possibly be necessary to carry out adaptations to the seat system.

5.1 Before driving for the first time...

Before you take your first trip, you should familiarise yourself well with the operation of the vehicle and with all operating elements. Take your time to test all functions and driving modes.



NOTE:

If installed, make sure to properly adjust and use the posture belt each time you use the wheelchair.

Sitting Comfortably = Driving Safely

Before each trip, make sure that:

You are within easy reach of all operating controls.

- **The battery charge is sufficient for the distance intended to be covered.**
- **The posture belt (if installed) is in perfect order.**

5.2 Parking and stationary

When parking your vehicle or if your vehicle is stationary for a prolonged period:

- Switch the vehicle's power system off (ON-/OFF key).
- Activate your anti-theft lock, if existing.

5.2.1 Parking brakes

Engaging the parking brake:

- Press lever (1) forward.

Disengaging the parking brake:

- Pull lever (1) backwards.

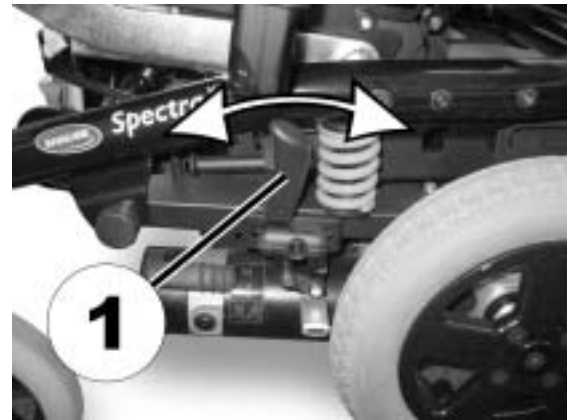

5.3 Taking Obstacles

5.3.1 Maximum obstacle height

You can find information about maximum obstacle heights in the chapter entitled "**Technical Specifications**" from page **151**.

5.3.2 Safety information when ascending obstacles



CAUTION: Danger of Tipping Over!

- *Never approach obstacles at an angle but at 90 degrees as shown below.*
 - *Put your backrest into an upright position before climbing an obstacle.*
-

5.3.3 The correct way to overcome obstacles

Ascending and descending

The same approach applies to both ascending and descending obstacles:

- Approach the obstacle or the kerb slowly and at a right angle.
- Stop shortly before the front wheels come into contact with the obstacle.
- Check the position of the front wheels. They must be in driving direction and at right angles to the obstacle.
- Approach slowly and keep at a consistent speed until the rear wheels have also passed over the obstacle.

Right



Wrong



5.4 Driving up and down gradients

For information concerning the maximum safe slope, please see chapter "**Technical Specifications**" starting on page 151.



WARNING: Danger of tipping over!

- *Only ever drive downhill at a maximum of 2/3 of the top speed. Avoid sudden changes of direction or abrupt braking when driving on slopes.*
 - *Always return the backrest of your seat or the seat tilt (if adjustable seat tilt is available) to an upright position before ascending slopes. We recommend that you position the seat backrest or the seat tilt slightly to the rear before descending slopes.*
 - *Always lower the lifter (if fitted) to its lowest position before ascending or descending a slope.*
 - *Never attempt to ascend or descend a slope on slippery surfaces or where there is a danger of skidding (such as wet pavement, ice etc).*
 - *Avoid trying to get out of the vehicle on an incline or a gradient.*
 - *Always drive straight in the direction the road or path you are on goes, rather than attempting to zigzag.*
 - *Never attempt to turn around on an incline or a slope.*
-



Braking distance is much longer on a downhill slope than on even terrain!

- *Never drive down a slope that exceeds the maximum safe slope (see chapter "**Technical Specifications**" on page 151).*
-

6 Pushing the mobility device in freewheel mode

The motors of the wheelchair are equipped with automatic brakes, preventing that the wheelchair starts rolling out of control when the joystick box is switched off. When pushing the wheelchair manually whilst freewheeling, the magnetic brakes must be disengaged.



NOTE:

Pushing the wheelchair by hand may require more physical force than expected (more than 100 N).

6.1 Disengaging motors



Danger of the vehicle running away!

- *When the motors are disengaged (for push operation whilst freewheeling), the electromagnetic motor brakes are deactivated! When the vehicle is parked, the levers for engaging and disengaging the motors must without fail be locked firmly into the "DRIVE" position (electromagnetic motor brakes activated)!*
-

The levers for disengaging the motors are located on each motor.

Disengaging the motor:

- Switch off remote.
- Push the engaging lever down (1). The motor is disengaged.

Engaging the motor:

- Pull the engaging lever (1) upwards. The motor is engaged.

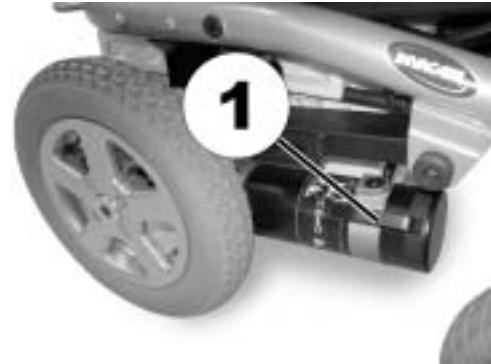

7 Remotes

Your wheelchair may be equipped with one of several different remotes. For information on the different functions and how to operate a particular remote, please see its corresponding User Guide.

8 Adjusting the wheelchair to the user's seating posture



Note

Initial setup should always be done by a healthcare professional. Adjustment by the user is only recommended after they have been given appropriate guidance by the healthcare professional.



CAUTION: Damage to wheelchair and accident hazard! Collisions between the legrests and the chassis, or between the footplates and the floor, can occur due to different combinations of adjustment options!

- *When adjusting the seat angle, lifter and legrests, ensure that the legrests cannot collide with the wheelchair chassis, and that the footplates cannot collide with the floor!*
-

8.1 Adjusting the armrests and the joystick box



CAUTION: Danger of the remote being pushed backwards during an accidental collision with an obstacle, such as a doorframe or table, and the joystick being jammed against the armpad if the position of the remote is adjusted and all screws are not completely tightened! This will cause the mobility device to drive forward uncontrollably and potentially injure the mobility device user and any person standing in the way!

- *When adjusting the position of the remote, always make sure to tighten all screws securely!*
- *If this should accidentally happen, immediately switch the mobility device electronics OFF at the remote!*

8.1.1 Adapting the remote to the length of the user's arm

The photo shows the armrest of the firm seat, other armrests are similar to this.

- Release wing screw (1).
- Adjust the remote by pushing it forwards or backwards to the required location.
- Retighten the screw.



8.1.2 Setting the height of the remote

8.1.2.1 High-End remote holder



Pre-requisites:

- 1x 6 mm Allen key
-

- Loosen the Allen screw (1).
- Adjust the remote to the desired height.
- Re-tighten the Allen screw.



8.1.3 Swivelling the remote to the side

If your wheelchair is fitted with a swing-away remote bracket, then the remote can be moved away to the side, for example to drive up close to a table.



8.1.4 Setting the height of the armrests

8.1.4.1 Firm seat unit



Requirements:

- 1x Phillips screwdriver
-

The armrest on the firm seat is fitted with a screw (1) which is used as a stop. The armrest height is adjusted using this stop.



- Release wing screw (2).
- Remove the armrest from the mounting.



- Remove the screw (1) using the Philipps screwdriver.
- Set the new armrest height by selecting a higher or lower screw hole.
- Retighten the screw.
- Introduce the armrest into the mounting again. Tighten the wing screw.
- Repeat the process for the other side if necessary.



8.1.4.2 Standard Seat unit

- Loosen the wing screw (1).
- Set the armrest to the desired height.
- Re-tighten wing screw.

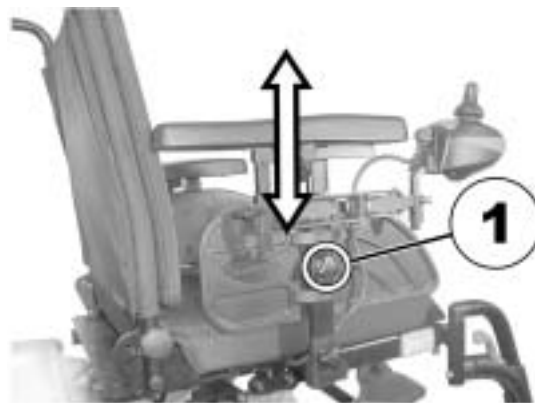

8.1.5 Setting the Hemi armrest rotation

Carrying out adjustments

- Swivel the armrest inwards or outwards.



8.1.6 Adjusting the width of the armrests

8.1.6.1 Firm seat unit



WARNING! Serious injury hazard if one of the armrests falls out of its bracket because they have been adjusted to a width which exceeds the permissible value!

- *The armrest width adjustment for the firm seat unit is limited on both sides by a spring-loaded pin. This limiting pin may only be pressed in to remove the armrest completely (e.g. for getting in and out) and never to extend the width adjustment!*
-

Carrying out adjustments

- Loosen clamping lever (1)
- Adjust armrest to required position.
- Retighten the clamping lever.
- Repeat this procedure for the second armrest.

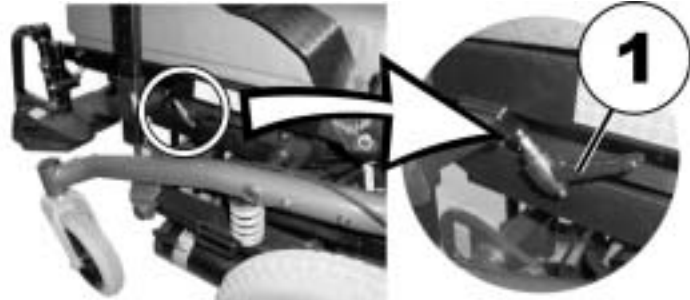

8.1.6.2 Standard Seat unit



WARNING! Serious injury hazard if one of the armrests falls out of its bracket because they have been adjusted to a width which exceeds the permissible value!



- *The width adjustment is fitted with small stickers with markings and the word "STOP"! The armrests must never be pulled out further than the point at which the word "STOP" is completely legible!*
- *Always tighten the fixing screws properly once adjustments have been completed!*



Requirements:

- Allen key 8 mm

Carrying out adjustments

- Loosen screw (1)
- Adjust armrest to required position.
- Retighten the screw.
- Repeat this procedure for the second armrest.

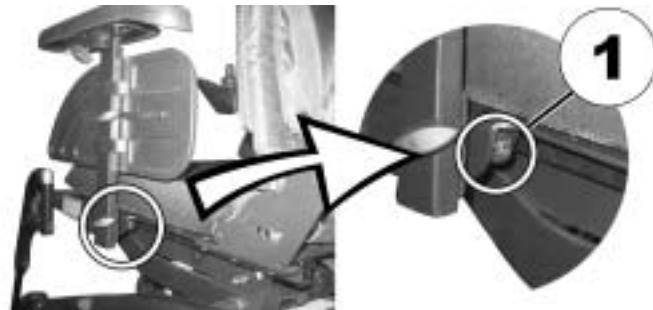

8.1.6.3 Flex II seat unit



WARNING! Serious injury hazard if one of the armrests falls out of its bracket because they have been adjusted to a width which exceeds the permissible value!



- *The width adjustment is fitted with small stickers with markings and the word "STOP"! The armrests must never be pulled out further than the point at which the word "STOP" is completely legible!*
- *Always tighten the fixing screws properly once adjustments have been completed!*



Requirements:

- Allen key 8 mm

Carrying out adjustments

- Loosen screw (1)
- Adjust armrest to required position.
- Retighten the screw.
- Repeat this procedure for the second armrest.

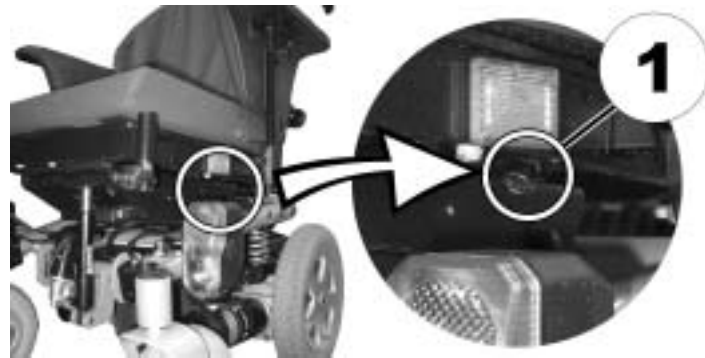

8.2 Adjusting the seat angle



CAUTION! Adjusting the seat tilt or the backrest angle changes the geometry of the mobility device and directly influences its dynamic stability!

- *For details regarding dynamic stability, negotiating gradients and obstacles and the correct adjustment of seat tilt or backrest angle, please see chapters "Taking Obstacles" on page 32 and "Driving up and down gradients" on page 34.*
-

8.2.1 Electric

Please consult the instruction manual for your remote for information about electric adjustment.

8.2.2 Manually using spindle

The manual seat angle adjustment has an adjustable range of 0° to 20°.

The seat angle is adjusted by means of a spindle, which is to be found at the front underneath the seat frame.

When adjusting the seat angle it should be ensured that at least 1cm of the threaded bolt always remains inside the spindle and is not completely unscrewed from the spindle.



NOTE

It is easier to adjust the angle of the seat when there is nobody sitting in the wheelchair.

The figure to the right shows the position of the spindle (1) for manual seat angle adjustment.

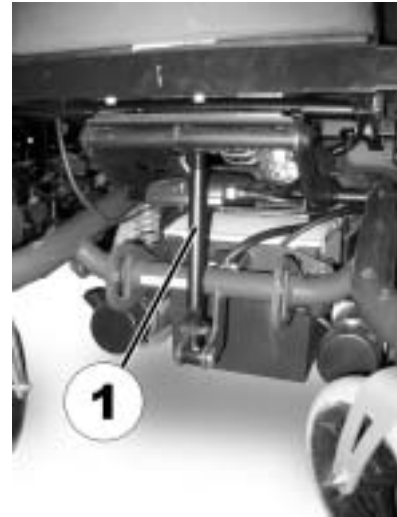

8.3 Adjusting the backrest



CAUTION! Adjusting the seat tilt or the backrest angle changes the geometry of the mobility device and directly influences its dynamic stability!

- *For details regarding dynamic stability, negotiating gradients and obstacles and the correct adjustment of seat tilt or backrest angle, please see chapters "Taking Obstacles" on page 32 and "Driving up and down gradients" on page 34.*

8.3.1 Adjusting the backrest angle using the perforated plate (standard seat)

- Pull the belt (1) to the rear. The locking pins (2, only the right-hand side visible in image) are pulled out of the perforated plates. The backrest can now be moved.
- Adjust the backrest to the required position.
- Release the belt again. The locking pins engage automatically.

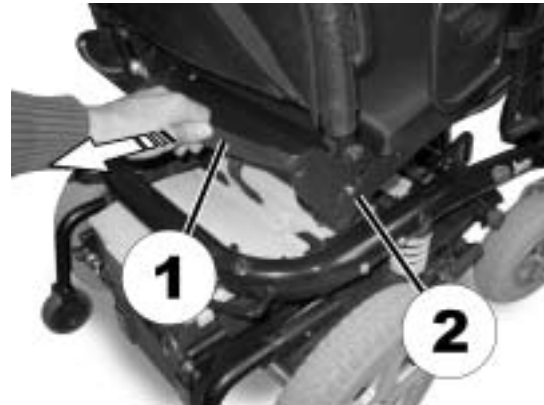

8.3.2 Adjusting the backrest (firm seat)

8.3.2.1 Electric

Please consult the instruction manual for your remote for information about electric adjustment.

8.3.2.2 Manual

The angle of the manually adjustable backrest is continuously adjustable between +2° and +22°.



Pre-requisites:

- 1x Open-end spanner 13 mm
 - 1x Phillips screwdriver
-

The angle of the manually adjustable backrest is adjusted on both sides by means of a knurled adjustment screw (1) and a limiting screw (2), which is fitted with a counter nut (3).

- Loosen the knurled screws (1) on both sides.
- Loosen the counter nut (3) of the limiting screw (2), using the open-end spanner 13 mm.
- Adjust the limiting screws (2) evenly on both sides to the desired backrest angle, using the Phillips screwdriver.
- Tighten the counter nut (3).
- Re-tighten the knurled screws.

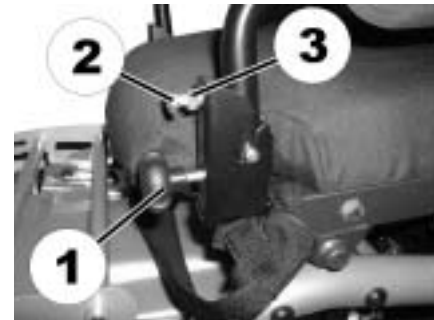

8.3.3 Adjusting the backrest using the gas pressure spring (Flex II seat)

The lever (1) for adjusting the backrest angle is located on the opposite side from the remote under the armrest. If, for example, the remote is installed on the right, the lever is located on the left.

- Pull the lever upwards. Adjust the backrest to the required angle.
- Release the lever again. The backrest engages again.



8.3.4 Adjusting the tension adjustable backrest upholstery

- Remove the backrest cushion (attached with Velcro strips) by pulling it up and off to access the adjustment straps.



- Adjust the tension of the individual straps as desired.
- Replace the backrest cushion.



8.4 The Lifter

The electric lifter is operated from the remote. Please refer to the remote manual for more information.



Information regarding operation of the lifter at temperatures of less than 0 °C

Invacare® mobility aids are fitted with safety mechanisms that prevent capacity overload of the electronic components. At operating temperatures below freezing point this can, in particular, lead to the lifter actuator being shut down after approx. 1 second operating time.

The lifter can be raised or lowered gradually by repeatedly operating the joystick. In many cases this generates sufficient heat for the actuator to operate as normal.



Note - speed limiter

The lifter is fitted with sensors which reduce the mobility device speed as soon as the lifter is raised above a certain point.

This takes place to guarantee the tipping stability of the mobility device and to avoid damage to the legrests.

If the speed limit is activated, a corresponding blink code is displayed on the remote or a reduced drive level is set automatically. Please refer to the remote manual for more information.

To reapply normal speed, run the lifter down until the status display stops blinking.

8.4.1 Explanation of symbols on lifter warning sticker.



Do not lean out when the lifter is raised!



Do not drive up or down slopes when the lifter is raised!



Do not allow any body parts to get under a raised seat!



Never drive with two people!



Never drive over uneven surfaces when the lifter is raised!

8.5 Adjusting the headrest



CAUTION: Injury hazard during use of the mobility aid as a vehicle seat if a headrest is wrongly adjusted or not installed! This can cause the neck to be hyperextended during collisions!

- *A headrest must be installed! The headrest optionally supplied for this mobility device by Invacare® is perfectly suitable for use during transport.*
- *The headrest must be adjusted to the user's ear height.*



- Loosen the clamping lever (1,2 or 3).
- Adjust the headrest to the required position.
- Retighten clamping lever.



8.5.1 Adjusting the position of the headrest or neckrest

The adjustment of the position is the same for all headrests and neckrests.



Pre-requisites:

- Allen key 5 mm
-
- Loosen the screws (1, 2) or the clamping lever (3).
 - Adjust the headrest or neckrest to the required position.
 - Retighten screws and clamping lever.

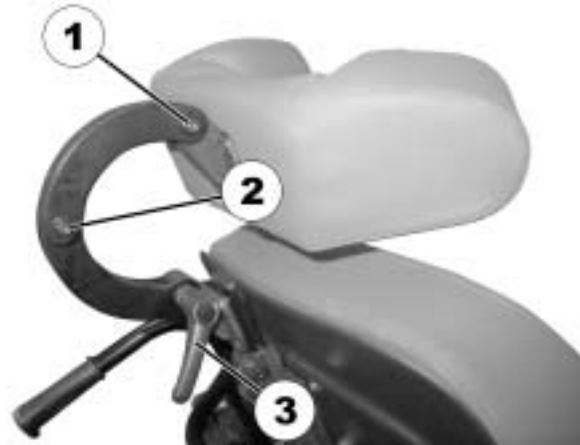

8.5.2 Adjusting the height of the headrest or neckrest

The adjustment of the height is the same for all headrests and neckrests.

- Loosen the thumb screw (1).
- Adjust the headrest or neckrest to the required height.
- Retighten thumb screw.



8.5.3 Adjusting the position of the headrest with cheek support sideways



Pre-requisites:

- Allen key 5 mm
-

- Loosen the Allen screw (1)
- Slide the headrest left or right to the required position.
- Retighten the Allen screw.



8.5.4 Adjusting the cheek supports

- Push the cheek supports inward or pull them out to the required position.



8.6 Postural belts

A postural belt is an option which can either be fixed to the wheelchair ex-works or can be retrofitted by your specialist dealer. If your wheelchair is fitted with a postural belt, your specialist dealer will have informed you about fitting and usage.

The postural belt is used to help the wheelchair user keep an optimum sitting position. Correct use of the belt assists the user in sitting securely, comfortably and well-positioned in the wheelchair, especially for such users who do not have such a good sense of balance while sitting.



NOTE:

We recommend using the postural belt whenever the wheelchair is used. The belt should be tight enough to ensure that you are sitting comfortably and that your body is in the correct sitting position.

8.6.1 Types of postural belts

Your wheelchair can be fitted with the following postural belt types ex-works. If your wheelchair has been fitted with a different belt to those listed below, please ensure that you have received the manufacturer's documentation with regard to correct fitting and use.

Belt with metal buckle, adjustable one side

Belt can only be adjusted on one side which can result in the buckle not sitting centrally.



Belt with metal buckle, adjustable both sides

Belt can be adjusted on both sides. This means that the buckle can be centrally positioned.



Belt with Velcro fastening

Adjustments are made using the Velcro fastening. For this reason no buckle is required on this belt.



8.6.2 Adjusting the postural belt correctly

- Ensure that you are sitting correctly, which means that you are sitting right at the back of the seat, your pelvis is positioned erect and as symmetrically as possible, not to the front, to the side or at one edge of the seat.
- Position the postural belt so that your hipbones can be easily felt above the belt.
- Adjust the belt length using one of the adjustment aids described above. The belt should be adjusted so that you can fit a flat hand between the belt and your body.
- The buckle should be positioned as centrally as possible. In doing so, please carry out adjustments on both sides as much as possible.
- Please check your belt every week to ensure that it is still in good working condition; to ensure it has no damage or wear, and that it is fixed properly to the wheelchair. If the belt is only fastened with a bolted connection, ensure that the connection has not loosened or undone. You can find more information about maintenance work on belts in the service manual, which is available from Invacare®.

8.7 Adjusting the trunk support (Flex II seat / firm seat)

The trunk supports can be adjusted in width, height and depth.

8.7.1 Adjusting the width

- Loosen the knobs (1) that hold the lateral supports.
- Adjust the supports to the desired width.
- Re-tighten the knobs.



8.7.2 Adjusting the height



Requirements:

- Allen key 5 mm
-

- Loosen the screws (1) that allow height adjustment of the lateral supports.
- Adjust the supports to the desired height.
- Re-tighten the screws.

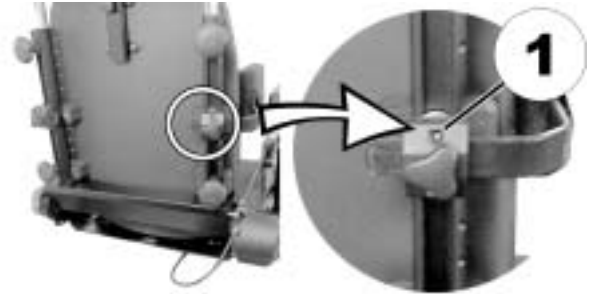

8.7.3 Adjusting the depth



Requirements:

- Allen key 5 mm
-

- Loosen the screws (1) that allows the support pads to slide forwards and backwards.
- Adjust the supports to the desired position.
- Re-tighten the screws.



8.8 Adjusting the height-adjustable push handle (Flex II seat)

- Loosen the knobs (1) that hold the push-handle.
- Adjust the handle to the desired height.
- Re-tighten the knobs.



8.9 Adjusting and removing the tray



CAUTION: Injury hazard or material damage if an electric wheelchair which is fitted with a table is transported in a vehicle!

- *If a table is fitted, always remove it before transporting the wheelchair.*



8.9.1 Laterally adjusting the tray

- Loosen the wing-screw (1).
- Adjust the tray towards the left or right.
- Re-tighten wing-screw.

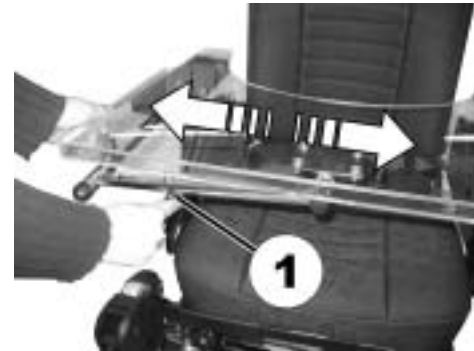

8.9.2 Adjusting the depth of the tray / removing the tray

- Loosen the wing-screw (1).
- Adjust the table to the desired depth (or remove it entirely).
- Re-tighten the screw.



8.9.3 Swinging the tray away to the side

The tray can be swivelled up and away to the side to allow the user to get in and out of the mobility device



CAUTION! Risk of injury! When the tray is raised it does not lock in place in this position!

- *Do not tilt the tray up and leave it leaning in this position.*
 - *Never attempt to drive with the tray tilted up.*
 - *Always lower the tray in a controlled manner.*
-

The tray can be swivelled upwards and pushed to the side as illustrated to enable getting on and off.



9 Adjusting footrests and legrests

9.1 Legrests or footrests attached to the side

9.1.1 Vari-F footrest

9.1.1.1 Swivelling the footrest outward and/or removing

The small unlocking button is located on the upper section of the footrest. When the footrest is unlocked, it can be swivelled inward or outward when getting into the wheelchair as well as being removed completely.

- Press the unlocking button (1) and swivel the footrest outward.
- Remove the footrest in an upward direction.



9.1.1.2 Setting the angle



PLEASE NOTE: Danger of injury due to incorrect adjustment of the footrests and legrests.

- *Before and during every journey it is imperative to ensure that neither the legrests nor the steering wheels contact the ground!*
-



Pre-requisites:

- 1x 6 mm Allen key
-

- Loosen the screw (1) using the Allen key.
- If the footrest cannot be moved after loosening the screw, position a metal pin in the designated borehole (2) and use a hammer to knock on this lightly. The clamping mechanism in the interior of the footrest will be released by this. Repeat the procedure from the other side of the footrest if necessary.



- Loosen the screw (1) using the Allen key.
- Set the desired angle.
- Re-tighten the screw.



9.1.1.3 Setting the end stop of the footrest



Pre-requisites:

- 1x 6 mm Allen key
 - 1x 10 mm open-ended spanner
-

The end position of the footrest is determined by means of a rubber stop (1).



The rubber stop can be screwed in or out (A) or pushed up or down (B).



- Use the Allen key to loosen the screw (1) and swivel the footrest upward in order to access the rubber stop.



- Use the open-ended spanner to loosen the counternut (1).



- Move the rubber stop to the desired position
- Re-tighten the counternut



- Move the footrest to the desired position.
- Re-tighten the screw.



9.1.1.4 Adjusting the length of the footrest



PLEASE NOTE: Danger of injury due to incorrect adjustment of the footrests and legrests.

- *Before and during every journey it is imperative to ensure that neither the legrests nor the steering wheels contact the ground!*
-



Pre-requisites:

- 1x 5 mm Allen key
-

- Use the spanner to loosen the screw (1).
- Adjust to the desired length.
- Re-tighten the screw.



9.1.2 Vari-A legrests

9.1.2.1 Swivelling the legrest outward and/or removing

The small unlocking button is located on the upper section of the legrest. When the legrest is unlocked, it can be swivelled inward or outward when getting into wheelchair as well as being removed completely.

- Press the unlocking button (1) and swivel the legrest outward.
- Remove the legrest in an upward direction.



9.1.2.2 Setting the angle



PLEASE NOTE: Danger of injury due to incorrect adjustment of the footrests and legrests.

- *Before and during every journey it is imperative to ensure that neither the legrests nor the steering wheels contact the ground!*
-

- Disengage the release handle (1).
- Adjust to the desired angle.
- Re-tighten the release handle.



9.1.2.3 Setting the end stop of the legrest



Pre-requisites:

- 1x 10 mm open-ended spanner
-

The end position of the legrest is determined by means of a rubber stop (A).



The rubber stop can be screwed in or out (A) or pushed up or down (B).



- Disengage the release handle (1) and swivel the legrest upward in order to access the rubber stop.



- Use the open-ended spanner to loosen the counternut (1).



- Move the rubber stop to the desired position
- Re-tighten the counternut



- Move the footrest to the desired position.
- Re-tighten the release handle.



9.1.2.4 Adjusting the length of the legrest



PLEASE NOTE: Danger of injury due to incorrect adjustment of the footrests and legrests.

- *Before and during every journey it is imperative to ensure that neither the legrests nor the steering wheels contact the ground!*
-



Pre-requisites:

- 1x 6 mm Allen key
-

- Use the spanner to loosen the screw (1).
- Adjust to the desired length.
- Re-tighten the screw.



9.1.2.5 Adjusting the depth of the calf plate

The depth of the calf plate can be adjusted via the holding plate. The holding plate hole combinations allow 5 different depth settings.



Pre-requisites:

- 1x 10 mm open-ended spanner
-
- Use the open-ended wrench to loosen the nut (1) and remove.
 - Adjust to the desired depth. Please observe that the round holes are intended for the calf plate retaining screw and the oblong holes for the aglet without thread.
 - Screw the nut back on and tighten.



9.1.2.6 Adjusting the height of the calf plate



Pre-requisites:

- 1x 4 mm Allen key
-

- Use the Allen key to loosen the screws (1).
- Adjust to the desired position.
- Re-tighten the screws.



9.1.2.7 Unlocking and swivelling the calf plate backward when alighting

- Press the calf plate straight down.



- Unlock the legrest and swivel outward. The calf plate swivels backward on its own.



- Lift leg over the heel strap and place on the ground.



9.1.2.8 Adjusting the angle adjustable foot plate



Pre-requisites:

- 1x 5 mm Allen key
-

- Use the Allen key to loosen both set screws on the foot plate.
- Adjust to the desired angle.
- Re-tighten the screws.



9.1.2.9 Adjusting the angle and depth adjustable foot plate



Pre-requisites:

- 1x 5 mm Allen key
-
- Use the Allen key to loosen the set screw on the foot plate (1).
 - Adjust the foot plate to the desired angle or depth.
 - Re-tighten the screw.



9.1.3 ADE legrests

9.1.3.1 Swivelling the legrest outward and/or removing

The small unlocking button is located on the upper section of the legrest. When the legrest is unlocked, it can be swivelled inward or outward when getting into wheelchair as well as being removed completely.

- Press the unlocking button (1) and swivel the legrest outward.
- Remove the legrest in an upward direction.



9.1.3.2 Setting the angle



PLEASE NOTE: Danger of crushing!

- *Do not reach inside the swivelling range of the legrest!*
-



PLEASE NOTE: Danger of injury due to incorrect adjustment of the footrests and legrests.

- *Before and during every journey it is imperative to ensure that neither the legrests nor the steering wheels contact the ground!*
-

The electrically height-adjustable legrests are operated using the remote. Please see the separate operating manual for your remote for more information.

9.1.3.3 Adjusting the length of the legrest



PLEASE NOTE: Danger of injury due to incorrect adjustment of the footrests and legrests.

- *Before and during every journey it is imperative to ensure that neither the legrests nor the steering wheels contact the ground!*
-



Pre-requisites:

- 1x 10 mm open-ended spanner
-

- Use the spanner to loosen the screw (1).
- Adjust to the desired length.
- Re-tighten the screw.



9.1.3.4 Adjusting the depth of the calf plate

The depth of the calf plate can be adjusted via the holding plate. The holding plate hole combinations allow 5 different depth settings.



Pre-requisites:

- 1x 10 mm open-ended spanner
-
- Use the open-ended wrench to loosen the nut (1) and remove.
 - Adjust to the desired depth. Please observe that the round holes are intended for the calf plate retaining screw and the oblong holes for the aglet without thread.
 - Screw the nut back on and tighten.



9.1.3.5 Adjusting the height of the calf plate



Pre-requisites:

- 1x 4 mm Allen key
-

- Use the Allen key to loosen the screws (1).
- Adjust to the desired position.
- Re-tighten the screws.



9.1.3.6 Unlocking and swivelling the calf plate backward when alighting

- Press the calf plate straight down.



- Unlock the legrest and swivel outward. The calf plate swivels backward on its own.



- Lift leg over the heel strap and place on the ground.



9.1.3.7 Adjusting the angle adjustable foot plate



Pre-requisites:

- 1x 5 mm Allen key
-

- Use the Allen key to loosen both set screws on the foot plate.
- Adjust to the desired angle.
- Re-tighten the screws.



9.1.3.8 Adjusting the angle and depth adjustable foot plate



Pre-requisites:

- 1x 5 mm Allen key
-
- Use the Allen key to loosen the set screw on the foot plate (1).
 - Adjust the foot plate to the desired angle or depth.
 - Re-tighten the screw.



9.1.4 Standard 80° footrest

9.1.4.1 Swivel the footrests outwards and/or remove them

The small release lever is to be found in the upper part of the legrest (1). When the legrest is released it can be swivelled inward or outward to facilitate access and also be removed completely.



- Push the release lever inward or outward. The legrest is released.
- Swivel the legrest inward or outward.
- To remove the legrest simply pull upward.



9.1.4.2 Adjusting the length



Pre-requisites:

- 1x 5 mm hexagon socket spanner
-
- Loosen the screw (1) using the Allen key, but do not remove completely.
 - Set the legrest to the desired length.
 - Re-tighten the screw.



9.1.5 Manually height-adjustable legrest

9.1.5.1 Swivelling the legrest outward and/or removing

The unlocking knob is located on the top section of the legrests. When the legrest is unlocked, it can be swivelled to the inside or outside to facilitate getting in, or can be completely removed.

- Press the unlocking knob (1) and remove the legrests upwards.

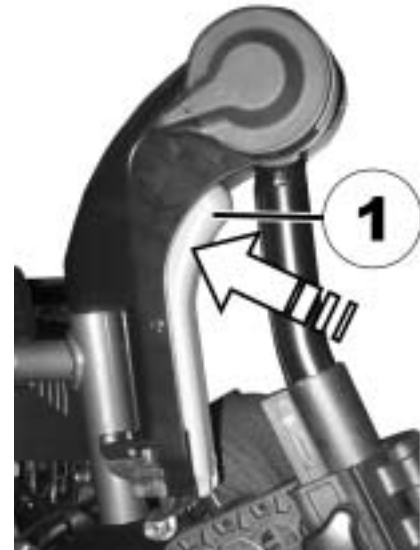

9.1.5.2 Setting the angle



PLEASE NOTE: Danger of crushing!

- *Do not reach inside the swivelling range of the legrest!*
-



PLEASE NOTE: Danger of injury due to incorrect adjustment of the footrests and legrests.

- *Before and during every journey it is imperative to ensure that neither the legrests nor the steering wheels contact the ground!*
-

- Press the unlocking lever (1) down. Adjust the legrest to the required angle.
- Release the unlocking lever. The legrest engages.



9.1.5.3 Adjusting the length of the legrest



PLEASE NOTE: Danger of injury due to incorrect adjustment of the footrests and legrests.

- *Before and during every journey it is imperative to ensure that neither the legrests nor the steering wheels contact the ground!*
-



Pre-requisites:

- 1x 5 mm hexagon socket spanner
-

- Loosen bolt (1) with the Allen key.
- Adjust to required length.
- Retighten the screw.



9.1.5.4 Adjusting the depth of the calf plate

The calf support has four depth settings.



Pre-requisites:

- 1x 4 mm Allen key
-
- Swivel the calf support to the front.
 - Release bolt (1) with the Allen key and remove.
 - Set the nut on the other side to the required depth.
 - Adjust the calf support to match the depth of the nut, put the screw back in and tighten.



9.1.5.5 Adjusting the height of the calf plate

- Loosen the hand screw (1).
- Adjust to required position.
- Retighten the wing nuts.

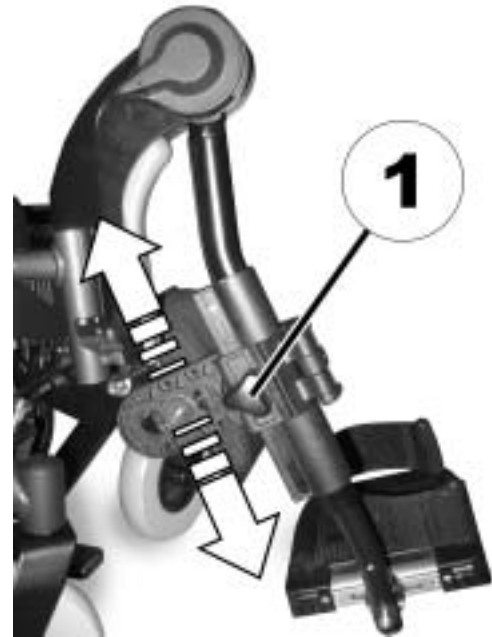

9.1.6 Adjusting the width of the legrests fixed to the side (Standard / Flex II seat)



Requirements:

- Jaw spanner 13 mm (standard seat)
 - Jaw spanner 10 mm (Flex II seat)
-

The screws that allow width adjustment of side-mounted legrests are located under the seat (1).

- Loosen the screws using the open-end spanner.
- Adjust the legrest to the desired position.
- Re-tighten the screws.



9.2 Legrests for the firm seat

9.2.1 Modifying the seat depth in the front by adjusting the position of the legrest support brackets

The seat depth in the front can be modified by adjusting the position of the legrest support brackets. Adjusting the position of the legrest support brackets is the same for all types of legrests.



Pre-requisites:

- 1x Allen key 4 mm
-

- Loosen the grub screw (1), using the Allen key.
- Release the wing screw (2).
- Set the position of the legrest support bracket to the desired depth.
- Re-tighten the screws.

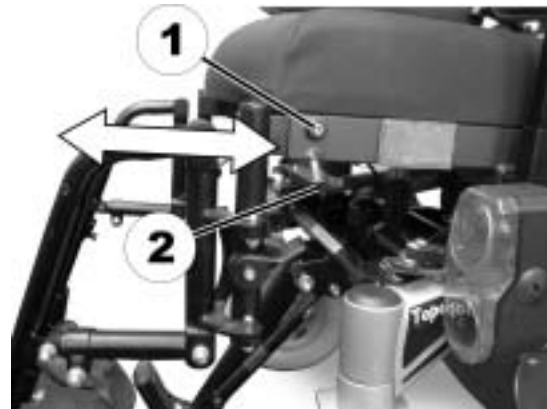

9.2.2 Standard / Junior / Mini Legrests (firm seat)

9.2.2.1 Adjusting the length of the legrest



PLEASE NOTE: Danger of injury due to incorrect adjustment of the footrests and legrests.

- *Before and during every journey it is imperative to ensure that neither the legrests nor the steering wheels contact the ground!*
-



Pre-requisites:

- 1x Open-ended spanner 13 mm
-
- Remove the plastic cover cap from the adjustment screw (1).
 - Loosen the screw, using the open-ended spanner 13 mm.
 - Set the legrest to the desired length. Take care not to rotate the lower part of the legrest in its support tube.
 - Re-tighten the screws.
 - Re-position the plastic cover cap.



9.2.3 Angle adjustable legrest

9.2.3.1 Adjusting the angle of the legrest



Pre-requisites:

- 1x open-ended spanner 13 mm
 - 1x open-ended spanner 10 mm
 - 1x Allen key 4 mm
-

- Loosen the fixation screws (1) of the pivotal points of the angle adjustment, using the open-ended spanner 10 mm and the Allen key 4 mm.
- Loosen the clamping screw (2) of the angle adjustment, using the open-ended spanner 13 mm.

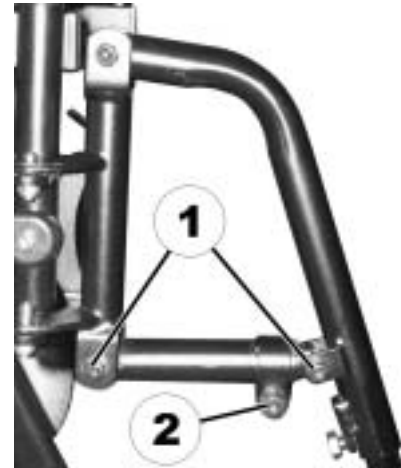

On the underside of the legrest hanger there is a slit (A) in the outer tube, which allows visual inspection.

When adjusting the angle, the inner tube (D) should only ever be pulled out so far that its end is flush with the edge (B) of the clamp (C).

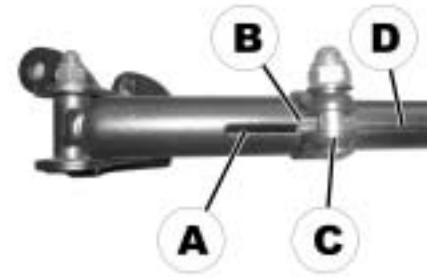

- Adjust legrest to the desired angle.
- Check the remaining length of the inner tube in the outer tube through the slit for visual inspection.
- Re-tighten all screws.



9.2.3.2 Adjusting the length of the legrest



PLEASE NOTE: Danger of injury due to incorrect adjustment of the footrests and legrests.

- *Before and during every journey it is imperative to ensure that neither the legrests nor the steering wheels contact the ground!*
-



Pre-requisites:

- 1x Open-ended spanner 13 mm
-

- Loosen the screw (1) using the 13 mm open-ended spanner.
- Set the legrest to the desired length. Take care not to rotate the lower part of the legrest in its support tube.
- Re-tighten the screw.



10 Electrical System

10.1 Electronics Protection System

The vehicle drive electronics is fitted with an overload protection.

If the drive is severely overloaded over a long period (e.g. during steep climbs) and, above all, at simultaneous high external temperatures, the electronic system can overheat. In this case, the vehicle performance is gradually reduced until it comes to a standstill. The status display shows a corresponding blink code (please refer to the instruction manual for your remote). If you switch the drive electronics off and then on again, the error message is deleted and the electronics can be switched on again. It can however take up to five minutes until the electronics has cooled down enough for the drives to apply their full performance.

If the drive is blocked due to an insurmountable obstacle, for example a kerb or similar which is too high, and the driver attempts to run the drive for more than 20 seconds against this obstacle, the electronic system switches the drives off to avoid damage. The status display shows a corresponding flash code (please refer to your remote instruction manual). If you switch the drive electronics off and then on again, the error message is deleted and the electronics can be switched on again.



NOTE

A defective main fuse may be replaced only after checking the entire electric system. An Invacare® specialised dealer must perform the replacement. You can find information on the fuse type in chapter "**Technical Specifications**" starting on page **151**.

10.2 Batteries

10.2.1 What you need to know about batteries

Power is supplied by two 12V batteries. The batteries are maintenance-free and only need regular charging.

New batteries should always be fully charged once before their first use. New batteries will be at their full capacity after having run through approx. 10 - 20 charging cycles. How fast the batteries will be discharged will depend on many circumstances, such as ambient temperature, condition of the surface of the road, tyre pressure, weight of the driver, way of driving and utilisation of lighting, etc.



NOTE

The batteries supplied with your electric vehicle are not hazardous goods. This classification is based on the German *GGVS Hazardous Goods Road Transport Ordinances*, and the *IATA/DGR Hazardous Goods Rail Transport / Air Transport Ordinances*. Batteries may be transported without restrictions, whether by road, rail or by air. Individual transport companies have, however, guidelines which can possibly restrict or forbid certain transport procedures. Please ask the transport company regarding each individual case.

Pay attention to the Battery Charge Indicator! Make sure to charge the batteries when the Battery Charge Indicator shows that battery charge is low. We recommend charging the batteries after each trip, as well as each night over night. Depending on the level of discharge, it can take up to 12 hours until the batteries are fully charged again.

Protect your charger from sources of heat such as heaters and direct sunlight. If the battery charger overheats, charging current will be reduced and the charging process delayed.

To avoid damaging the batteries, never allow them to be fully discharged. Do not drive on heavily discharged batteries if it is not absolutely necessary, as this will strain the batteries unduly and shorten their life expectancy.

In case your vehicle is not used for a longer period of time, then the batteries must be charged at least once a month to maintain a full charge. Alternatively, the vehicle can stay connected to the charger. The batteries cannot be overcharged with the specified charger.

Please use only charging devices in Class 2. This class of chargers may be left unattended during charging. All charging devices which are supplied by Invacare® comply with these requirements.

10.2.2 Charging the batteries

Please see the instruction manuals for your remote and battery charger for the position of the charging socket and further information about charging the batteries.



WARNING: Danger of explosion and destruction of batteries if the wrong battery charger is used!

- *Only ever use the battery charger supplied with your vehicle, or a charger that has been approved by Invacare®.*

Danger of electric shock and damage to the battery charger if it is allowed to get wet!

- *Protect the battery charger from water.*
- *Always charge in a dry environment.*

Danger of short circuit and electric shock if the battery charger has been damaged!

- *Do not use the battery charger if it has been dropped or damaged.*

Danger of fire and electric shock if a damaged extension cable is used!

- *Only ever use an extension cable if it is absolutely necessary. In case you must use one, make sure it is in good condition.*
-

- Switch off the electric wheelchair at the remote. Connect the battery charger to the remote. The charging socket is located underneath the remote.
- Connect the battery charger to the power supply and switch on if necessary.
- Once charging is complete, first disconnect the battery charger from the power supply, then disconnect the plug from the remote.

10.2.3 How to handle damaged batteries correctly



WARNING:

Corrosion and burns from acid leakage if batteries are damaged!

- *Remove clothes that have been soiled by acid immediately.*

After contact with skin:

- *Immediately wash affected area with lots of water.*

After contact with eyes:

- *Immediately rinse eyes under running water for several minutes; consult a physician.*
-

- Always wear safety goggles and appropriate safety clothing when handling damaged batteries.
- Place damaged batteries in an acid-resistant receptacle immediately after removing them.
- Only ever transport damaged batteries in an appropriate acid-resistant receptacle.
- Wash all objects that have come into contact with acid with lots of water.

Disposing of dead or damaged batteries correctly

Dead or damaged batteries can be given back to your dealer or directly to Invacare®.

11 Maintenance

The term „Maintenance“ means any task performed to ensure that a medical device is in good working order and ready for use as intended. Maintenance encompasses different areas, such as everyday care and cleaning, inspection checks, repair tasks and refurbishment.



NOTE:

Have your vehicle checked once a year by an authorised Invacare® dealer in order to maintain it's driving safety and roadworthiness.

11.1 Cleaning the mobility device

When cleaning the mobility device, pay attention to the following points:

- Only use a damp cloth and gentle detergent.
- Do not use any abrasive or scouring agents.
- Do not subject the electronic components to any direct contact with water.
- Do not use any high-pressure cleaning devices.

Disinfection

Spray or wipe disinfection using a tested and recognised product is permitted. A list of the current permitted disinfectants is available from the Robert Koch Institute at <http://www.rki.de>.

11.2 Inspection checks

The following table lists inspection checks that should be performed by the user and their intervals. If the mobility device fails to pass one of the inspection checks, please refer to the chapter indicated or contact your authorised Invacare® dealer. A more comprehensive list of inspection checks and instructions for maintenance work can be found in the Service Manual for this device, which can be obtained from Invacare®. That Manual, however, is intended to be used by trained and authorised service technicians, and describes tasks which are not intended to be performed by the user.

11.2.1 Before each use of the mobility device

Item	Inspection check	Action
Signal horn	<ul style="list-style-type: none"> • Check for correction function. 	<ul style="list-style-type: none"> • Contact your dealer.
Lighting system	<ul style="list-style-type: none"> • Check that all lights, such as turn indicators, headlamps and tail lights, are functioning correctly. 	<ul style="list-style-type: none"> • Contact your dealer.
Battery case locking system	<ul style="list-style-type: none"> • Check to ensure that the battery case locking system is functioning correctly. Locking pins must be completely engaged in the holes provided for them (see chapter "Transporting the wheelchair without occupants" on page 138)! 	<ul style="list-style-type: none"> • Contact your dealer.
Batteries	<ul style="list-style-type: none"> • Make sure the batteries are charged. See the User Manual provided with your remote for a description of the Battery Charge Indicator. 	<ul style="list-style-type: none"> • Charge the batteries (see chapter "Charging the batteries" on page 115).

11.2.2 Weekly

Item	Inspection check	Action
Armrests /side parts	<ul style="list-style-type: none"> • Check that armrests are firmly attached in their holders and do not wobble. 	<ul style="list-style-type: none"> • Tighten the screw or clamping lever that holds the armrest (see chapter "Adjusting the armrests and the joystick box" on page 39). • Contact your dealer.
Tyres (pneumatic)	<ul style="list-style-type: none"> • Check that the tyres are undamaged. 	<ul style="list-style-type: none"> • Contact your dealer.
	<ul style="list-style-type: none"> • Check that the tyres are inflated to the correct pressure. 	<ul style="list-style-type: none"> • Inflate the tyre to the correct pressure (see chapter "Technical Specifications" on page 151). • Repair the inner tube if you have a flat tyre (see chapter "Repair Instructions" on page 122) or contact your dealer to have it repaired.
Tyres (puncture-proof)	<ul style="list-style-type: none"> • Check that the tyres are undamaged. 	<ul style="list-style-type: none"> • Contact your dealer.
Anti-Tippers	<ul style="list-style-type: none"> • Check that anti-tippers are firmly attached and do not wobble. 	<ul style="list-style-type: none"> • Contact your dealer.

11.2.3 Monthly

Item	Inspection check	Action
All upholstered parts	<ul style="list-style-type: none"> • Check for damage and wear. 	<ul style="list-style-type: none"> • Contact your dealer.
Removable legrests	<ul style="list-style-type: none"> • Check whether the legrests can be fixed securely and whether the loosening mechanism is properly operable (see chapter "Adjusting footrests and legrests" on page 72). 	<ul style="list-style-type: none"> • Contact your dealer.
	<ul style="list-style-type: none"> • Check that all adjustment options function properly (see chapter "Adjusting footrests and legrests" on page 72). 	<ul style="list-style-type: none"> • Contact your dealer.
Castors	<ul style="list-style-type: none"> • Check that castors rotate and swivel freely. 	<ul style="list-style-type: none"> • Contact your dealer.
Drive wheels	<ul style="list-style-type: none"> • Check that the drive wheels rotate without wobbling. It is easiest to have someone stand behind the mobility device and observe the drive wheels as you drive away from them to do this. 	<ul style="list-style-type: none"> • Contact your dealer.
Electronics and connectors	<ul style="list-style-type: none"> • Check all cables for damage and all connecting plugs for snug fit. 	<ul style="list-style-type: none"> • Contact your dealer.

11.3 Repair Instructions



Important information about maintenance work tools!

Some maintenance work which is described in this manual and can be carried out by the user without problems require the correct tools for proper work. If you do not have the correct tool available we do not recommend that you try to carry out the relevant work. In this case, we urgently recommend that you contact an authorised specialist workshop.

The following are instructions on maintenance and repairs that can be performed by the user. For the specifications of spare parts please see "**Technical Specifications**" on page **151**, or consult the Service Manual, available from Invacare® (in this connection please see the addresses and phone numbers in section "**How can you get in touch with Invacare®?**" on page **2**). In case you require assistance, please contact your Invacare® Dealer.

11.3.1 Repairing a flat tyre



WARNING: Danger of damage or injury if the vehicle is accidentally set into motion during repairs!

- *Switch the power off (ON/OFF Button)!*
 - *Engage the motors!*
 - *Secure the vehicle against rolling away by placing wedges under the wheels!*
-

11.3.1.1 Repairing a flat tyre at the front (tyre type 280/250-4)



Pre-requisites:

- Allen key 5 mm
 - Open-ended spanner 13 mm
 - Repair kit for inner tube tyres **or** a new inner tube.
 - Talcum powder
-

Removing the wheel

- Jack up the mobility device (place a wooden wedge under the frame).
- Loosen and remove the screw (1) using the Allen key on one side and the open-ended spanner on the other side (for countering).
- Pull the wheel from the fork



NOTE:

Installation is carried out in reverse order. Please ensure that the wheel is re-fitted on the same side and in the same running direction as removed.

Repairing a flat tyre

- Unscrew valve cap.
- Depressurise tyre by pressing in the pin in the valve .
- Unscrew the 5 Allen screws (1).
- Remove the tyre with inner tube from the wheel rim halves.
- Repair inner tube and replace, or insert new.



NOTE

If the old inner tube is to be repaired and re-used, and has become wet during repair, you can make replacement easier by sprinkling the inner tube with a little talcum powder.

- Insert the wheel rim halves from outside into the tyre.
- Pump up the tyres a little.
- Insert the Allen screw once again, and screw the wheel rims together tightly. Avoid crushing the inner tube!
- Ensure that the tyre outer is seated correctly.
- Pump the tyre up to the prescribed pressure.
- Check that the tyre is seated correctly once again.
- Screw the valve cap back on.
- Refit the wheel.

11.3.1.2 Repairing a flat tyre at the rear (wheel rim type 3.00-8")



Injury hazard! If the wheel is insufficiently secured during fitting, it can come off while driving!

- *Always tighten the torx screws which secure the wheel to the hub to a torque of 30 Nm when refitting the drive wheels!*
 - *Secure all bolts using a suitable screw blocker system (e.g. Loctite 243)!*
-



Requirements:

- torque wrench with ...
 - Allen bit 5 mm
 - torx bit T40
 - repair kit for tyre repair **or** a new inner tube
 - talcum powder
 - screw blocker Loctite (e.g. Loctite 243)
-

Removing the wheel

- Raise the vehicle and place wooden blocks under it to support it.
- Remove the countersunk screw (1) using the torx bit.
- Pull the wheel off the axle.



EXPLOSION HAZARD! The wheel explodes if the air pressure has not been released from the wheel before the wheel rim is removed!

- *Always ensure that you have completely released the air pressure by pressing the pin in the centre of the valve firmly in!*
-

Repairing punctured tyres

- Remove the valve cap.
- Let the air escape completely out of the tyre by pressing the pin in the centre of the valve firmly in.
- Remove the 5 cylinder head screws (rear of wheel, 2).
- Remove the wheel rim halves from the wheel.
- Remove the inner tube from the wheel.
- Repair the inner tube and re-fit it, or replace it with a new one.

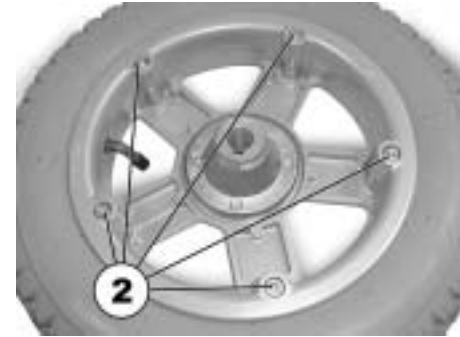

NOTE

If the old inner tube has been repaired and is to be used again, and became wet during repair, it is easier to replace it if it is lightly dusted with talcum powder beforehand.



NOTE

Refitting takes place in reverse order. Always ensure that the wheel is replaced on the same side as it came from, and that it is facing in the same direction.

- Apply the wheel rim halves to the wheel again.
- Inflate the tyre a little.
- Place the cylinder head screws in the wheel rim and tighten them to 10 Nm. Ensure that the inner tube is not clamped between the wheel rim halves.
- Ensure that the tyre is contacting the wheel rim directly.
- Inflate the tyre to the recommended pressure.
- Ensure that the tyre is still closely contracting the wheel rim.
- Screw the valve cap on again.
- Fit the wheel again.
- Place the torx screws in position with a screw blocker system and tighten them to 30 Nm.

12 Transport



CAUTION: Injury hazard or material damage if an electric wheelchair which is fitted with a table is transported in a vehicle!

- *If a table is fitted, always remove it before transporting the wheelchair.*



CAUTION: Danger of death or serious injury to the mobility device user and potentially any other nearby occupant of the vehicle, if a mobility device is secured using a 4-point tie-down system available from a third party supplier and the unladen weight of the mobility device exceeds the maximum weight for which the tie-down system is certified!

- *Make sure the weight of the mobility device does not exceed the weight for which the tie-down system is certified. Consult the tie-down manufacturer's documentation.*
- *If you are unsure how much your mobility device weighs, then you must have it weighed using calibrated scales.*

12.1 Transferring the wheelchair to a vehicle



WARNING: Danger of tipping over, if the wheelchair is transferred to a vehicle using a ramp that exceeds the maximum safe slope, or if the backrest is not in an upright position during transfer!

- *If the wheelchair has to be transferred to a vehicle using a ramp that exceeds the maximum safe slope (see chapter "Technical Specifications" starting on page 151), then a winch must be used. An attendant can then safely oversee and assist the transfer process.*
 - *If no winch is installed, then the wheelchair must not be transferred to a vehicle using a ramp that exceeds the maximum safe slope.*
 - *Alternatively, a tail lift installed in the vehicle may be used.*
 - *Only ever transfer the wheelchair to a vehicle with the backrest in an upright position. Ensure that the total weight of the mobility aid including the user does not exceed the highest permissible weight for the platform lift.*
 - *Only ever run the wheelchair with the seat back in the upright position, seat lifter lowered and the seat tilting in the upright position into the transport vehicle (please refer to chapter "Driving up and down gradients" on page 34).*
-
- Drive or push your wheelchair into the transport vehicle using a suitable ramp.

12.2 Use of the wheelchair as a seat in a vehicle



Please note

In order to use a wheelchair as a motor vehicle seat, it needs to be equipped with attachment points to enable anchoring in the motor vehicle. These accessories may be included in the standard scope of wheelchair order and delivery in some countries (UK for example), but may also be obtained from Invacare® as an option in other countries.

This electric wheelchair complies with the requirements of ISO 7176-19:2001 and may be used as a vehicle seat in connection with an anchoring system that has been checked and approved in accordance with ISO 10542. The wheelchair has undergone a crash test in which it was anchored in the transporting vehicle's direction of travel. Other configurations were not tested. The crash test dummy was secured using pelvic and upper body safety belts. Both types of safety belt should be used in order to minimise the risk of injuries to head or upper body. It is imperative that the wheelchair is inspected by an authorised dealer before being used again after being involved in a crash. Alterations to the wheelchair anchoring points may not be carried out without the manufacturer's permission.



Caution: There is a danger of injury if the wheelchair is not properly secured during use as a vehicle seat!

- *If possible, the user should always leave the wheelchair to use a vehicle seat and the safety belts provided with the vehicle.*
 - *The wheelchair should always be anchored facing in the transport vehicle's intended direction of travel.*
 - *The wheelchair must always be secured in accordance with the wheelchair and anchoring system manufacturers' operating manual.*
 - *Always remove and secure any accessory parts fixed to the wheelchair such as chin controls or tables.*
 - *If your wheelchair is equipped with an angle adjustable backrest, then it must be placed in an upright position.*
 - *Fully lower elevated legrests, if fitted.*
 - *Fully lower the seat lifter, if fitted.*
-



WARNING: Danger of injury exists if a powerchair that is not equipped with spill-proof batteries is transported in a vehicle!

- *Only ever use spill-proof batteries!*
-



WARNING: Danger of injury or damage to the wheelchair or to the transporting vehicle, if the legrests are in a raised position while the wheelchair is used as a vehicle seat!

- *Always completely lower height-adjustable legrests, if fitted.*
-

12.2.1 How the wheelchair is anchored in a vehicle for use as a vehicle seat

The electric wheelchair is fitted with four anchoring points, which are labelled with the symbol shown on the right. Snap hooks or belt loops can be used for fixation.



- Secure the wheelchair at the front (1) and at the rear (2) with the anchoring system belts. The kerb climber does not have to be removed.
- Secure the wheelchair by tensioning the belts in accordance with the anchoring system manufacturer's instruction manual.

Front (with kerb climber)

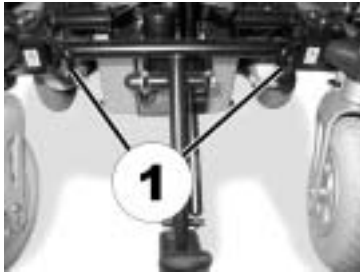

Front (without kerb climber)

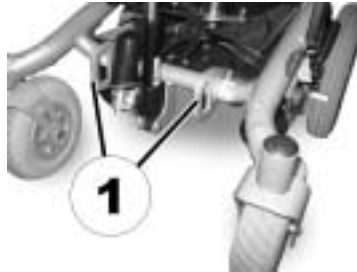

Rear (only left-hand side visible in picture)



12.2.2 How the user is secured within the wheelchair



CAUTION: There is a danger of injury if the user is not properly secured within the wheelchair!

- *Even if the wheelchair is fitted with a postural belt, this is no substitute for a proper safety belt which complies with ISO 10542 in the transport vehicle. Always use the safety belt installed in the transport vehicle.*
 - *Safety belts must be in contact with the user's body. They must not be held at a distance from the user's body using parts of the wheelchair such as armrests or wheels. Refer to the illustration on page 136.*
 - *Safety belts must be pulled as tightly as possible without causing the user discomfort. Refer to the illustration on page 136.*
 - *Safety belts must not be positioned while twisted.*
 - *Ensure that the third seatbelt anchorage point is not fixed directly to the vehicle floor, but to one of the vehicle uprights.*
-



CAUTION: Injury hazard during use of the mobility aid as a vehicle seat if a headrest is wrongly adjusted or not installed! This can cause the neck to be hyperextended during collisions!

- *A headrest must be installed! The headrest optionally supplied for this mobility device by Invacare® is perfectly suitable for use during transport.*
- *The headrest must be adjusted to the user's ear height.*





Seat belts may not be held at a distance from the user's body using parts of the wheelchair such as armrests or wheels.

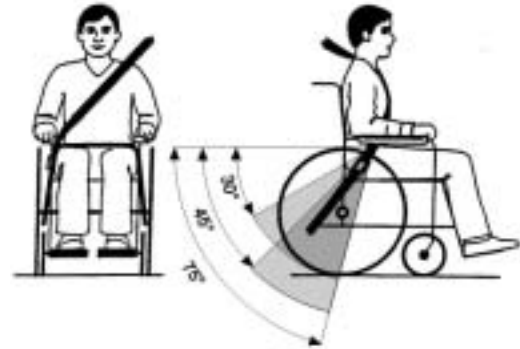

The pelvic belt should be positioned in the area between the user's pelvis and thighs so that it is unobstructed and not too loose. The ideal angle of the pelvic belt to the horizontal is between 45° and 75°. The maximum permissible angle is between 30° and 75°. The angle should never be less than 30°!

The safety belt installed in the transporting vehicle should be applied as shown in the illustration at right.

- 1) Centre line of the body
- 2) Centre of the sternum

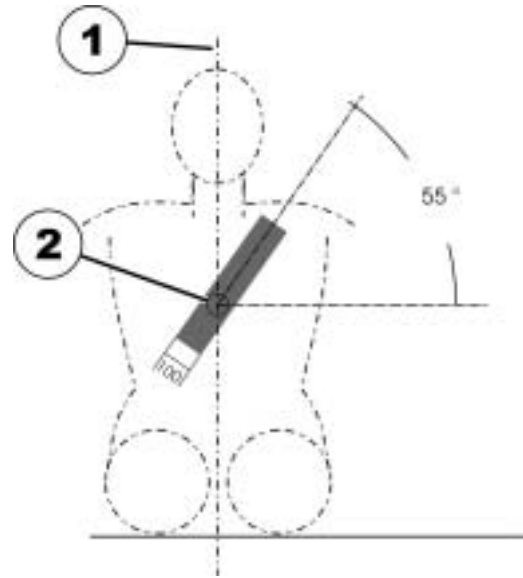

12.3 Transporting the wheelchair without occupants



CAUTION: Injury hazard!

- *If you are unable to fasten your electric wheelchair securely in a transport vehicle, we recommend that you do not transport it!*
-

- Before transporting your wheelchair, make sure the motors are engaged and that the Joystick Box is switched off.
- We urgently recommend securing the wheelchair to the floor of the transporting vehicle.

12.3.1 Preparing the wheelchair for transport without occupants.

Please proceed as follows to prepare the wheelchair for transport:

- Remove legrests (please refer to the chapter concerning legrests)
- Remove the battery case
- Tip the backrest forwards
- Remove the seat if necessary

The wheelchair is reassembled in reverse order to the above.

12.3.1.1 Removing the batteries

- Pull the rear battery case backwards using the belt. The locking system opens automatically when doing so.

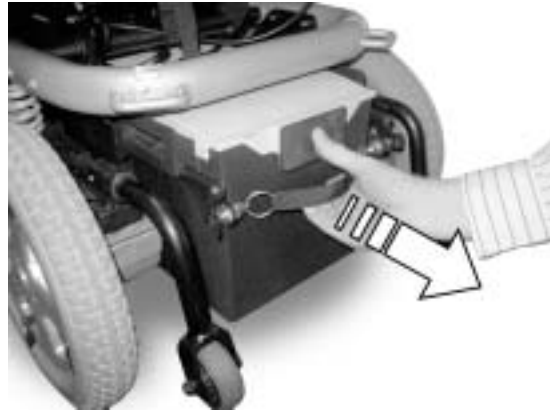

- Pull the battery cases out using the side handles.



- Pull the front battery case backwards using the belt and pull it out using the handles.



12.3.1.2 Folding the backrest forwards (standard seat)

- Pull the belt (1) to the rear. The locking pins (2, only the right-hand side visible in image) are pulled out of the perforated plates. The backrest can now be moved.

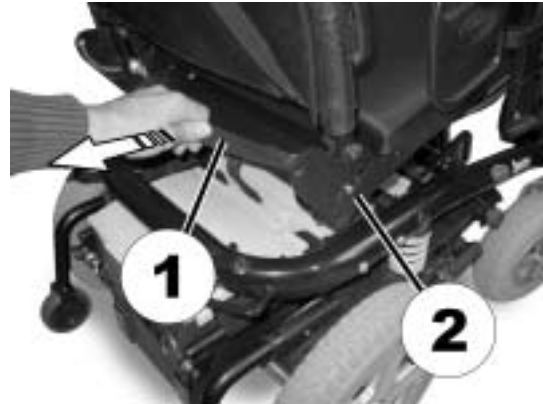

- Push the backrest completely to the front.
- The locking pins engage automatically.in



12.3.1.3 Removing the seat (not possible for versions fitted with lifter)



CAUTION: Danger of damage to wheelchair if the seat cannot be folded up or forwards without collision!

- *Remove legrests first!*
 - *Ensure that the legrest attachments do not hinder the seat when folding up! If necessary, vary the seat tilting!*
-

- Unlock the seat (the unlocking belt is located under the seat at the rear).



- Fold the seat upwards.



- Pull the remote cable plug out of the electronics system.



- Remove the seat upwards. Depending on the type, the seat can weigh between 16 and 23 kg. Get the help of the second person if the seat is too heavy to lift alone.



12.3.1.4 Reassembling the wheelchair



NOTE:

The wheelchair is reassembled in reverse order to the above.

12.3.1.5 Special information about reassembly

- When reassembling, ensure that the seat guide forks (1) are placed precisely on the stay bar in the front area.



- Ensure that there are no cables in the area around the rear stay bar (1) to avoid cable damage.



- Guide the remote cable under the seat support and connect it to the electronics system.
- Fold the seat down. It must audibly engage.



CAUTION: Injury hazard if the seat locking system does not completely engage!

- *Make absolutely sure that the locking system is correctly engaged! To do this, pull the seat upwards! It must be completely immobile!*
-

- If the backrest has an electrical recliner, refasten the motor to the backpost.



CAUTION: Injury hazard if the clevis pin of the motor of the electrical recliner is not correctly secured! An incorrectly secured pin can come off and the backrest can unexpectedly fold back, which can lead to injuries.

- *Make absolutely sure that you insert the R-clip to secure the clevis pin correctly! The clip must fit snugly around the pin! See the illustrations below:*



- When inserting the battery cases, please ensure that the guide rods (1) fit exactly in the guide channels (2) provided at the side of the battery cases, and that they are not underneath these!.
- To do this, first place the front of the battery case on the guide rods and then push the assembly in!



NOTE:

Once the wheelchair is reassembled, you must ensure that the locking system on the rear battery case has completely engaged. Check the correct seating of the locking pins! Also check the power supply. To do this, switch the wheelchair on at the remote. If the electric wheelchair is not ready to drive, check that the battery case has been fitted correctly!

13 Refurbishment

The product is suitable for refurbishment. Actions to be carried out:

- Cleaning and disinfection. Please see chapter "**Maintenance**" on page **117**.
- Inspection according to service plan. Please consult service instructions, available from Invacare®.
- Adaptation to the user. Please see chapter "**Adjusting the wheelchair to the user's seating posture**" on page **38**.

14 Disposal

- The equipment wrapping is potentially recyclable.
- The metal parts are used for scrap metal recycling.
- The plastic parts are used for plastic recycling.
- Electric components and printed circuit boards are disposed of as electronic scrap.
- Exhausted or damaged batteries can be returned to your medical equipment supplier or Invacare®.
- Disposal must be carried out in accordance with the respective national legal provisions.
- Ask your city or district council for details of the local waste management companies.

15 Technical Specifications

Permissible Operating and Storage Conditions	
Temperature range for operation according to ISO 7176-9:	<ul style="list-style-type: none"> • -25 ... +50 °C
Temperature range for storage according to ISO 7176-9:	<ul style="list-style-type: none"> • -40 ... +65 °C

Electrical system	
Motors	<ul style="list-style-type: none"> • 2 x 230W
Batteries	<ul style="list-style-type: none"> • 2 x 12V / 50Ah (C20) leakproof/AGM
Main fuse	<ul style="list-style-type: none"> • 50 A strip fuse for each battery box

Charging device	
Output current	<ul style="list-style-type: none"> • 8A ± 8%
Output voltage	<ul style="list-style-type: none"> • 24V nominal (12 cells)
Input voltage	<ul style="list-style-type: none"> • 200 – 250V nominal
Operating temperature (surroundings)	<ul style="list-style-type: none"> • -25° ... +50°C
Storage temperature	<ul style="list-style-type: none"> • -40° ... +65°C

Drive wheel tyres	
Tyre type	<ul style="list-style-type: none"> • 200x45 (puncture-proof)
Tyre type	<ul style="list-style-type: none"> • 230x60 (2.80/2.50-4) pneumatic (air pressure 3.5 bar)
Tyre type	<ul style="list-style-type: none"> • 230x60 (2.80/2.50-4) puncture-proof

Driving characteristics	
Speed	<ul style="list-style-type: none"> • 6 km/h / 10km/h
Max. safe slope	<ul style="list-style-type: none"> • 15.8% (9°) Stat. / 10.5 % (6°) Dyn.
Max. climbable obstacle height	<ul style="list-style-type: none"> • 6 cm (10cm with kerb climber)
Turning circle	<ul style="list-style-type: none"> • 160 cm (without lifter) • 163 cm (with lifter)
Drive range in accordance with ISO 7176 ***	<ul style="list-style-type: none"> • 30 km

Dimensions	Standard	Firm seat	Flex II
Total height (without lifter)	• 94 cm	• 105 cm	• 98 cm
Total height (with lifter)	• 95 - 125 cm	• 106 - 136 cm	• 99 - 129 cm
Drive unit width	• 59 cm / 62 cm *2		
Total seat width (with standard armrests)	-	-	-
Seat width 33 cm	-	• 55 cm	-
Seat width 39 cm	-	• 60 cm	
Seat width 43 cm	• 64 cm		
Seat width 48 cm	-	-	• 69 cm
Total length (incl. standard legrests)	<ul style="list-style-type: none"> • 116 cm (without lifter) • 163 cm (with lifter) 		
Seat height ****	<ul style="list-style-type: none"> • 46 cm (without lifter) • 47 - 77 cm (with lifter) 		
Seat width (armrest adjustment range in brackets)	<ul style="list-style-type: none"> • 43 cm (44 - 48 cm**) 	<ul style="list-style-type: none"> • 43 cm (44 - 48 cm**) • 39 cm (40 - 44 cm**) • 33 cm (34 - 37 cm) 	<ul style="list-style-type: none"> • 38 cm (39) • 43 (44 - 48 cm**) • 48 (49 - 53 cm**)

Dimensions	Standard	Firm seat	Flex II
Seat depth	• 41 / 46 / 51cm	• 30 / 33 / 35 / 38 / 44 / 48cm	• 43 - 51cm
Backrest height ****	• 48 / 54 cm	• 43 / 57 cm	• 56 cm
Seat cushion thickness	• 5 cm	• 7 cm	• 7 cm
Backrest angle	• -2°, 10°, 22°, 34°, 46°	• 0° ... 30° (electrical) • 2° ... 22° (manual)	• 0° - 30° (without lifter) • 0° ... 20° (with lifter) *****
Armrest height	• 25-35 / 29-39 cm		
Seat angle, electronic adjustment	• 0° ... +20° (without lifter) • 0° ... +28° (with lifter) *****		
Seat angle, manual adjustment	• 0° ... +20°		

Footrests and legrests		
Type	Length	Angle
Junior 70	• 23-28	• 70
Mini 90	• 23-28	• 90
Standard 70	• 35-42	• 70
Standard 80	• 38-48	• 80
Vari F	• 32-49	• 0-70
Vari A	• 32-49	• 0-70
ADE (electric)	• 32-49	• 0-75
Angle-adjustable	• 37-47	• 50-65
Height-adjustable (manual)	• 38-48	• 0-70

Weight	
Kerb weight with fixed seat angle and standard seat *****	<ul style="list-style-type: none"> • 98 kg (without lifter) • 130 kg (with lifter)

Component weights	
Seat unit	<ul style="list-style-type: none"> • approx. 23 kg
Chassis	<ul style="list-style-type: none"> • approx. 40 kg
Batteries	<ul style="list-style-type: none"> • approx. 15 kg per battery

Loading	
Max. load	<ul style="list-style-type: none"> • 130 kg

Axle loads	
Max. front axle load	<ul style="list-style-type: none"> • 110 kg
Max. rear axle load	<ul style="list-style-type: none"> • 140 kg

* Approximate.

** Width adjustable for side panel adjustment.

*** Note: The drive range of an electric wheelchair is strongly influenced by external factors, such as the charging state of the batteries, surrounding temperature, local topography, road surface characteristics, tyre pressure, weight of user, drive style and use of batteries for lighting, servos etc.

**** Measured without seat cushion

***** The actual kerb weight depends on the fittings your mobility aid has been supplied with. Every Invacare® mobility aid is weighed when leaving the works. Please refer to the nameplate for the kerb weight (including batteries) measured.

***** As soon as the lifter is raised above a certain point you can adjust the seat and backrest angles only at a combined total of max. 15°.

16 Inspections Performed

It is confirmed by stamp and signature that all jobs listed in the inspection schedule of the Service and Repair Instructions have been properly performed. The list of the inspection jobs to be performed can be found in the Service Manual which is available through Invacare®.

<u>Delivery Inspection</u>	<u>1st Annual Inspection</u>
Stamp of authorised Dealer / Date / Signature	Stamp of authorised Dealer / Date / Signature
<u>2nd Annual Inspection</u>	<u>3rd Annual Inspection</u>
Stamp of authorised Dealer / Date / Signature	Stamp of authorised Dealer / Date / Signature
<u>4th Annual Inspection</u>	<u>5th Annual Inspection</u>
Stamp of authorised Dealer / Date / Signature	Stamp of authorised Dealer / Date / Signature

Order No. of this Manual: 1528224.DOC
Release Date: 12.11.09

English